

20000

500 1602-001

STD



KEITHLEY INSTRUMENTS, INC.



INSTRUCTION MANUAL

**MODEL 261**

PICOAMPERE SOURCE

## **WARRANTY**

We warrant each of our products to be free from defects in material and workmanship. Our obligation under this warranty is to repair or replace any instrument or part thereof which, within a year after shipment, proves defective upon examination. We will pay domestic surface freight costs.

To exercise this warranty, call your local field representative or the Cleveland factory, DDD 216-248-0400. You will be given assistance and shipping instructions.

## **REPAIRS AND RECALIBRATION**

Keithley Instruments maintains a complete repair service and standards laboratory in Cleveland, and has an authorized field repair facility in Los Angeles and in all countries outside the United States having Keithley field representatives.

To insure prompt repair or recalibration service, please contact your local field representative or the plant directly before returning the instrument.

Estimates for repairs, normal recalibrations, and calibrations traceable to the National Bureau of Standards are available upon request.

## TABLE OF CONTENTS

Section	Page	Section	Page
1. GENERAL DESCRIPTION . . . . .	1	4-2. Range Resistors . . . . .	21
1-1. General . . . . .	1	4-3. Kelvin-Varley Divider . . . . .	21
1-2. Features . . . . .	1	4-4. Voltage Supply . . . . .	21
1-3. Applications . . . . .	2	5. SERVICING . . . . .	23
1-4. Specifications . . . . .	2	5-1. General . . . . .	23
1-5. Accessories . . . . .	3	5-2. Servicing Schedule . . . . .	23
1-6. Equipment Shipped . . . . .	3	5-3. Parts Replacement . . . . .	23
2. OPERATION . . . . .	5	5-4. Troubleshooting . . . . .	23
2-1. Front Panel Controls and		5-5. Procedures to Guide	
Terminals . . . . .	5	Troubleshooting . . . . .	24
2-2. Rear Panel Controls and		6. CALIBRATION . . . . .	25
Terminals . . . . .	5	6-1. General . . . . .	25
2-3. Preliminary Procedures . . . . .	5	6-2. Calibration Schedule . . . . .	25
2-4. Operating Procedures and		6-3. Voltage Supply Adjustment . . . . .	25
Accuracy Considerations . . . . .	6	6-4. Verification of Multiplier	
2-5. Output Connections . . . . .	7	Switch Settings . . . . .	26
2-6. Input Voltage Drop for Feed-		6-5. Verification of High	
back and Shunt-Type Picoam-		Megohm Resistors . . . . .	27
meters . . . . .	8	6-6. Range Calibration . . . . .	28
2-7. Compensation for Input Voltage		7. ACCESSORIES . . . . .	33
Drop of Feedback-Type Pico-		7-1. General . . . . .	33
ammeters . . . . .	11	7-2. Model 4003 Rack Mounting Kit . . . . .	33
2-8. Compensation for Input Volt-		7-3. Model 4004 Dual Rack Mount-	
age Drop of Shunt-Type High-		ing Kit . . . . .	33
Impedance Picoammeters . . . . .	12	7-4. Model 3004 Dual Bench	
2-9. Compensation for Input Volt-		Mounting Kit . . . . .	35
age Drop of Shunt-Type Low-		8. REPLACEABLE PARTS . . . . .	39
Impedance Picoammeters . . . . .	13	8-1. Replaceable Parts List . . . . .	39
2-10. Compensation for Voltage		8-2. How to Order Parts . . . . .	39
Coefficient . . . . .	13	Model 261 Replaceable	
2-11. Compensation for Temperature		Parts List . . . . .	40
Coefficient . . . . .	15	Model 2611 Replaceable	
3. APPLICATIONS . . . . .	17	Parts List . . . . .	43
3-1. General . . . . .	17	Model 261 Schematic	
3-2. Current Suppression . . . . .	17	Diagram 18323E . . . . .	45
3-3. Galvanometric Measurements . . . . .	18	Repair Form . . . . .	47
3-4. Ohmmeter Calibration . . . . .	18	*Change Notice . . . . .	Last Page
4. CIRCUIT DESCRIPTION . . . . .	21	*Yellow Change Notice sheet is included	
4-1. General . . . . .	21	only for instrument modifications af-	
		fecting the Instruction Manual.	



## SECTION 1. GENERAL DESCRIPTION

### 1-1. GENERAL.

a. The Keithley Model 261 Picoampere Source is a secondary standard for use in calibrating dc picoammeters. Its output is from  $10^{-14}$  ampere to  $1.1 \times 10^{-4}$  ampere in eight decade ranges. The Source has 3-digit resolution for outputs from  $10^{-12}$  to  $10^{-4}$  ampere.

b. Output current accuracy is  $\pm 0.25\%$  of setting from  $10^{-7}$  to  $1.1 \times 10^{-4}$  ampere, and ranges to  $\pm 1.6\%$  of setting from  $10^{-14}$  to  $10^{-12}$  ampere. These accuracies include high-megohm resistor drift for three months after calibration; input voltage drop considerations (paragraph 2-4) were excluded.

c. The Model 261 is line operated; the low side of the output can be floated to avoid ground loops or for use in ungrounded systems. Current is derived from a variable voltage source and a selectable range resistor. The voltage supply uses solid-state components throughout, and it is highly regulated for stability.

### 1-2. FEATURES.

a. Source voltage of the Picoampere Source is up to 11 volts, which permits accurate calibration of picoammeters with up to a 10-millivolt input voltage drop without using a correction calculation.

b. The high-megohm resistance standards are selected for stability. Individual temperature coefficients and resistance values are measured and supplied with the instrument.

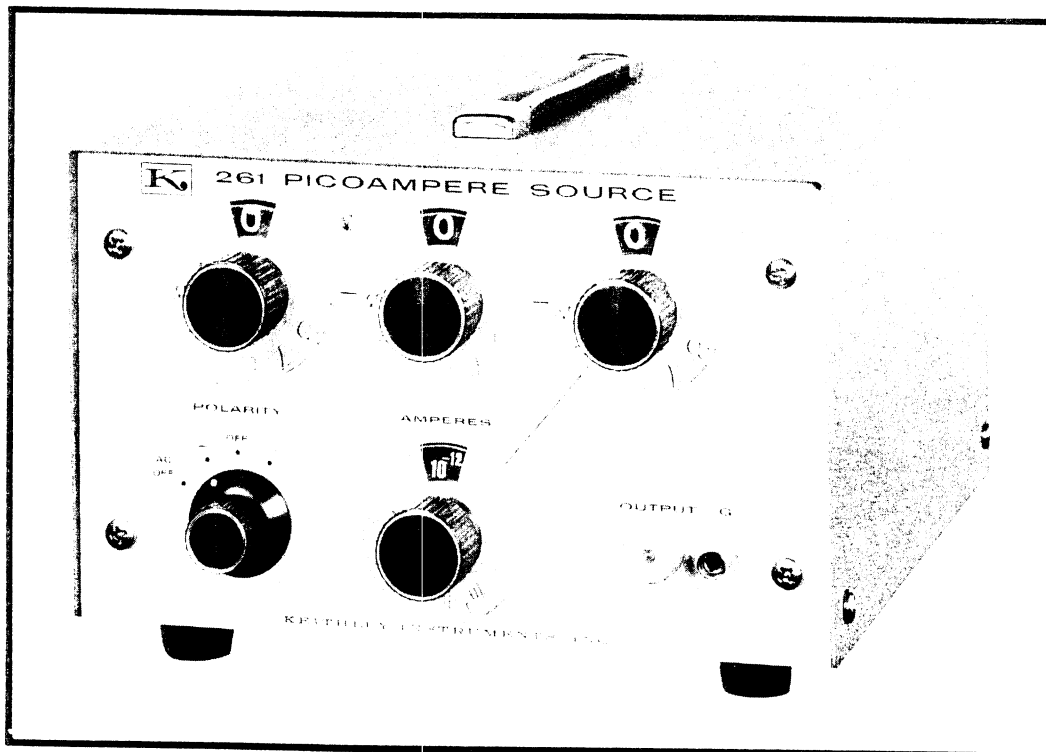

FIGURE 1. Keithley Instruments Model 261 Picoampere Source.

c. The guarded range resistor compartment allows using the resistance standards to check the accuracy of ohmmeters up to  $10^{12}$  ohms.

1-3. APPLICATIONS. (Also, refer to Section 3.)

a. Primarily, the Model 261 is used in calibrating picoammeters with full-scale ranges anywhere from  $10^{-14}$  to  $10^{-4}$  ampere.

b. The Source may also be used as an accurate current source for zero suppression. When used with the Keithley Model 610B Electrometer, it can suppress up to 1000 times full scale. Zero suppression permits easy observation of small variations in the suppressed current.

c. Galvanometric measurements are a special case of zero suppression. In this case, the picoammeter is used as a null detector and the unknown current is read directly from the Model 261 dials. With the Model 610B as a null detector, currents as low as  $10^{-12}$  ampere can be measured to  $\pm 0.6\%$ .

d. Ohmmeters may be calibrated using the certified resistance standards of  $10^5$  to  $10^{12}$  ohms in the Model 261. Guarding of the connections to the resistance standards is possible to reduce leakage errors at high resistances.

e. High impedance voltmeters, such as electrometers, may be calibrated using the Model 261 as a voltage source with an output impedance of 100 kilohms. The 3-dial divider provides accuracies from 0.1% from 1 to 11 volts to 0.2% from 0.1 to 0.99 volt.

1-4. SPECIFICATIONS.

OUTPUT:  $10^{-14}$  ampere to  $1.1 \times 10^{-4}$  ampere, positive or negative, in eight decade ranges.

ACCURACY: Exclusive of input drop considerations (see paragraph 2-4).

Range, ampere	Accuracy with 1.00 MULTIPLIER Switch Setting (1-Volt Source Voltage)	Worst-Case Accuracy With MULTIPLIER Switch Setting Other Than 1.00
$10^{-7}$ to $1.1 \times 10^{-4}$	$\pm 0.25\%$	$\pm 0.25\%$
$10^{-8}$ to $10^{-7}$	$\pm 0.5\%$	$\pm 0.5\%$
$10^{-9}$ to $10^{-8}$	$\pm 0.6\%$	$\pm 0.8\%$
$10^{-10}$ to $10^{-9}$	$\pm 0.6\%$	$\pm 1.1\%$
$10^{-11}$ to $10^{-10}$	$\pm 0.6\%$	$\pm 1.3\%$
$10^{-12}$ to $10^{-11}$	$\pm 0.6\%$	$\pm 1.6\%$
$10^{-14}$ to $10^{-12}$	—	$\pm 1.6\%$

LONG-TERM STABILITY: Will operate within stated specifications for three months after calibration. After three months add 0.15% per month to  $10^{-7}$  through  $10^{-14}$  ampere accuracy specification.

TEMPERATURE COEFFICIENT:  $\pm 0.01\%/^{\circ}\text{C}$ ,  $15^{\circ}\text{C}$  to  $30^{\circ}\text{C}$  on  $10^{-7}$  to  $10^{-5}$  ampere ranges. Approximately  $-0.1\%/^{\circ}\text{C}$  on  $10^{-12}$  ampere to  $10^{-8}$  ampere ranges. Exact value for these ranges supplied with instrument.

WARM-UP TIME: One hour.

LINE REGULATION: 0.01% for 10% change in line voltage.



SOURCE VOLTAGE: 0 to 11 volts in 0.01-volt steps.

RESOLUTION: Three significant figures from  $10^{-12}$  ampere to  $1.1 \times 10^{-4}$  ampere.

RANGE RESISTORS:  $10^5$  ohms to  $10^{12}$  ohms in decade steps,  $\pm 5\%$ .

RANGE RESISTOR ACCURACY: Value given on Calibration Certificate.  
 $\pm 0.5\%$ ,  $10^8$  ohms to  $10^{12}$  ohms;  
 $\pm 0.1\%$ ,  $10^7$  ohms to  $10^6$  ohms;  
 $\pm 0.02\%$ ,  $10^5$  ohms.

OUTPUT ISOLATION: Low to ground: Greater than  $10^9$  ohms shunted by 0.001 microfarad.

CERTIFICATION: A Calibration Certificate is furnished including range resistor values, thermal coefficients, temperature and date of calibration. Certification traceable to the National Bureau of Standards is also available.

CONNECTORS: Output: uhf type. Low and Ground: Binding posts.

POWER: 105-125 or 210-250 volts (switch selected); 50-1000 cps; 6 watts.

DIMENSIONS, WEIGHT: 5-1/2" high x 8-3/4" wide x 10" deep; net weight, 8 pounds.

ACCESSORIES SUPPLIED: Model 2611 Test Cable, 2 feet long with two male uhf connectors on each end.

#### 1-5. ACCESSORIES.

a. Model 2611 Test Cable is supplied with the instrument to provide a convenient means of connecting the Model 261 to the instrument to be calibrated. It includes two uhf-type plugs (Keithley Part No. CS-49).

b. Model 2612 Calibration Cable connects the Model 261 to the Keithley Model 515 Megohm Bridge for range resistor measurements.

c. Several mounting kits are available. The Model 4003 Rack Mounting Kit converts the Model 261 for mounting in a standard 19-inch rack. The Model 4004 Dual Rack Mounting Kit is for rack mounting two Model 261's or a Model 260 Nanovolt Source and a Model 261 in one rack frame. Total dimensions for units in the Model 4004 Kit are 5-1/4 inches high x 19 inches wide x 10 inches deep. The Model 3004 Dual Bench Mounting Kit will hold two Model 261's or a Model 260 Picoampere Source and a Model 261 in one convenient configuration for bench use. The dual instruments will measure 5-1/2 inches high x 17-1/2 inches wide x 10 inches deep. See Section 7 for photographs and installation instructions.

d. Model 6106 Electrometer Connection Kit contains a group of the most useful leads and adapters for electrometer measurements. See Section 7 for a complete description.

1-6. EQUIPMENT SHIPPED. The Model 261 Picoampere Source is factory-calibrated. It will remain within its rated specifications for at least three months after the date of shipment. The signed Certificate of Compliance and Calibration furnished with each Source lists exact range resistor values, high megohm serial numbers and calibration data. The shipping carton also contains the Instruction Manual and the Model 2611 Test Cable.

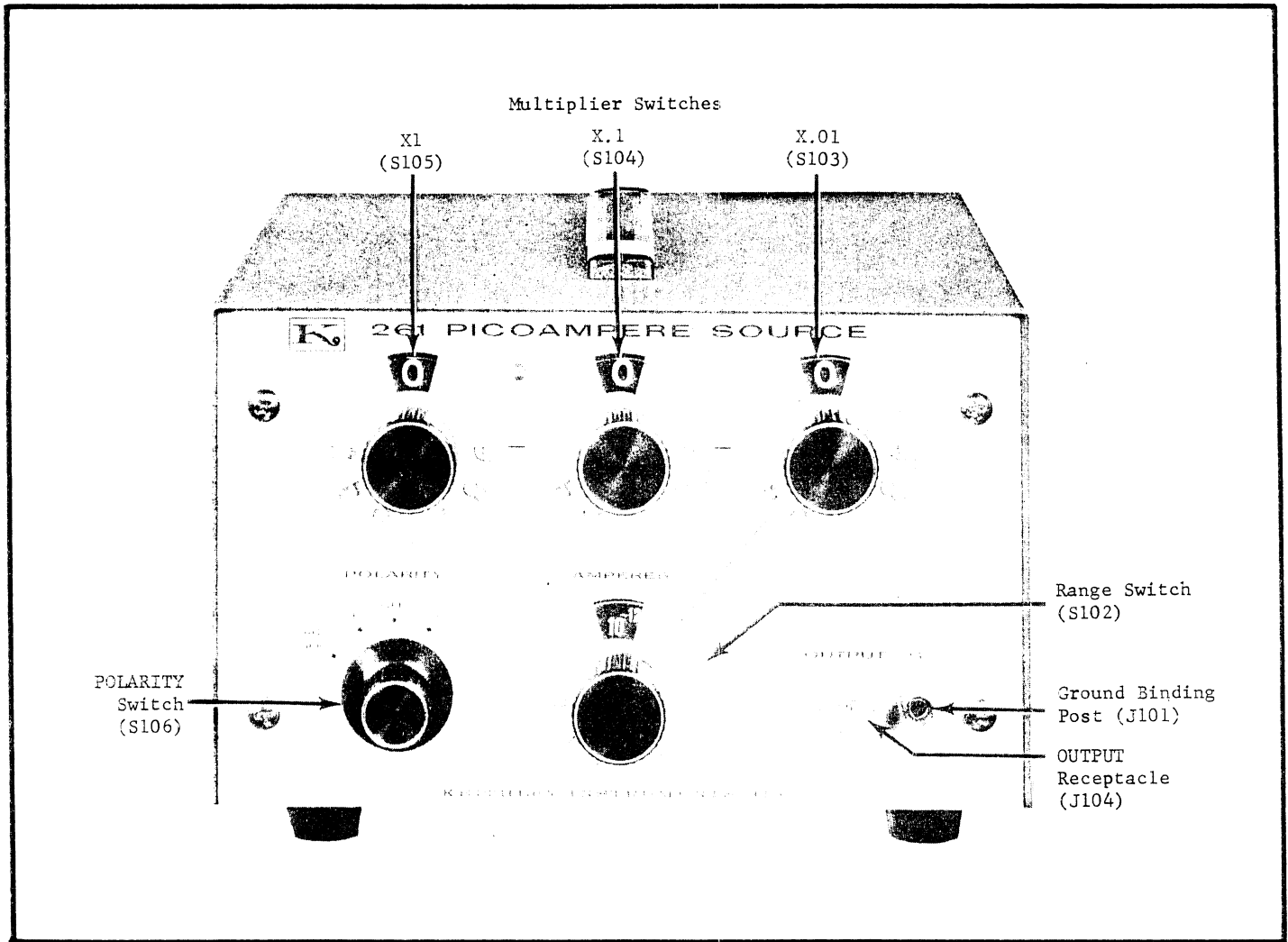

FIGURE 2. Model 261 Front Panel Controls and Terminals. Circuit designations refer to the schematic diagram.

## SECTION 2. OPERATION

### 2-1. FRONT PANEL CONTROLS AND TERMINALS. (See Figure 2.)

a. POLARITY Switch. The POLARITY Switch has four positions: the + and - positions provide for either positive or negative current outputs. In the AC OFF setting, the Model 261 power is disconnected. When the Switch is set to OFF, the voltage supply remains on but there is no output current. The output resistance of the instrument for this setting is the reciprocal of the Range Switch setting regardless of the Multiplier Switch settings.

b. Range Switch. The Range or AMPERES Switch selects one of eight decade current ranges from  $10^{-5}$  to  $10^{-12}$  ampere. When the Multiplier Switches are set to 1.00, the Range Switch indicates the output current. The reciprocal of the setting is the nominal value of the range resistor being used.

c. Multiplier Switches. Three switches provide multiplying values for the Range Switch. The illuminated decimal point between the first and second dials is also the pilot lamp. The Switches vary the output with a 3-decade Kelvin-Varley divider. The first (units) and third (hundredths) switches each have 11 positions from 0 to 10; the second (tenths) switch has 10 positions from 0 to 9.

d. OUTPUT Receptacle. The OUTPUT Receptacle is a Teflon-insulated uhf-type connector. The threaded or low side is not connected to chassis ground unless the COM and GND Terminals at the rear of the Source are connected. A chassis ground terminal, G, is next to the OUTPUT Receptacle.

### 2-2. REAR PANEL CONTROLS AND TERMINALS.

a. 117-234 Switch. The screwdriver-operated slide switch sets the Model 261 for 117 or 234-volt ac power lines.

b. FUSE. For 105-125 volt operation, use a 1/8 ampere, 3 AG slow blow fuse. For 210-250 volt operation, use a 1/16 ampere, 3 AG slow blow fuse.

c. Power Cord. The 3-wire power cord with the NEMA approved 3-prong plug provides a ground connection for the cabinet. An adapter for use from 2-terminal outputs is provided.

d. COM and GND Terminals. The green COM Binding Post is connected to the shield of the OUTPUT Receptacle. The black GND Binding Post is connected to the chassis. A shorting link is provided to connect the two terminals to ground the low-side of the output.

### 2-3. PRELIMINARY PROCEDURES.

#### NOTE

Use the Model 2611 Test Cable to connect the Picoampere Source to the picoammeter. The Cable makes connections more convenient and minimizes noise and leakage. Also, the Model 6106 Electrometer Connection Kit contains many items to increase accuracy and convenience during measurements.

a. Check the 117-234 Switch and the Fuse for the proper ac line voltage. Connect the power cord.

b. Set the Model 261 controls as follows:

POLARITY Switch	OFF
Range Switch	Desired current range
Multiplier Switches	1.00

c. Connect the Source to the picoammeter, using the Model 261 Test Cable. Follow guide points outlined in paragraph 2-5. Floating operation also is given there.

d. Set the POLARITY Switch to + or - to obtain the current of the desired polarity.

2-4. OPERATING PROCEDURES AND ACCURACY CONSIDERATIONS. The Range Switch setting times the Multiplier Switch setting gives the Model 261 current output. The accuracy of the output, however, depends upon several factors.

a. Output connections from the Source to the picoammeter are very important, especially for the lower ranges. The accuracy of the current at the Model 261 OUTPUT Receptacle will mean little if poor or improper hookups are made from the Source to the picoammeter.

b. Picoammeter Input Voltage Drop.

1. For specified output accuracy the voltage drop of the picoammeter must be less than 1/1000 of the internal source voltage of the Model 261. The internal source voltage in volts is read directly from the Multiplier Switch setting, regardless of the Range Switch setting. The voltage drop of the picoammeter is a characteristic of that instrument: it can be found in its instruction manual or it must be calculated.

2. For picoammeters with a 1-millivolt or less voltage drop, set the Model 261 Multiplier Switches to 1.00. For a voltage drop between 10 and 1 millivolts, set the Multiplier Switches to 10.00 and set the Range Switch one decade lower. This setting does not affect the Model 261 accuracy for outputs greater than  $10^{-8}$  ampere. For lower outputs see sub-paragraph c below. Note that even for a voltage drop 1/100 of the source voltage, an error of only 1% is added to the specified Picoampere Source accuracy.

c. Setting the Multiplier Switches to 1.00 insures the most accurate output current, given the proper voltage drop/source voltage ratio. Setting the Multiplier Switches to other than 1.00 does not affect the accuracy for outputs greater than  $10^{-8}$  ampere. Below this, an error due to the voltage coefficient of the high-megohm resistors will affect the current output. In all cases, however, the Model 261 output accuracy is at least that of the worst-case accuracy listed in the accuracy specification in paragraph 1-4.

d. When the Model 261 is used on the  $10^{-9}$  to  $10^{-12}$  ranges at other than the calibrated temperature — stated on the Calibration Certificate furnished with the Source — a discrepancy in the output current will occur. On other ranges the effect is not significant.

e. The following paragraphs list ways to avoid introducing calibrating errors and state compensations for these errors. Normally, accuracies of  $\pm 0.25\%$  at  $10^{-7}$  ampere to  $\pm 0.7\%$  at  $10^{-12}$  ampere are readily obtainable. In those cases where you must deviate from the operating procedures, compensations may be made to increase accuracy. Even without the compensation, though, the accuracy will be as good as or better than the worst-case accuracy specified in paragraph 1-4.

## 2-5. OUTPUT CONNECTIONS.

## NOTE

Make all connections carefully between the Model 261 and picoammeters having fast response speeds. Tie down cables; avoid vibrations. Cable movements cause meter jitter on the  $10^{-9}$  ampere and lower ranges due to capacitance changes.

a. For currents  $10^{-8}$  ampere and less, carefully shield the output connections and the input connection of the picoammeter. Unless the shielding is thorough, any change in the electrostatic field near the input circuitry will cause definite meter disturbances on the picoammeter.

b. Use high resistance, low-loss materials — such as Teflon (recommended), polyethylene or polystyrene — for insulation. The insulation leakage resistance of test fixtures and leads should be several orders of magnitude higher than the internal resistance of the source. If it is not, leakage losses will cause lower readings. Coaxial cables used should be a low-noise type which employ a graphite or other conductive coating between the dielectric and the surrounding shield braid. Amphenol-Borg Electronics Corporation, Microdot, Inc., and Simplex Wire and Cable Company make satisfactory types.

## NOTE

Ground loops may occur when equipment connected to the Model 261 has one side of the input grounded. In this case disconnect the shorting link between the Model 261 COM and GND Binding Posts. The low side of the output then floats; output isolation from low to ground is greater than  $10^9$  ohms shunted by 0.001 microfarad with the link removed.

c. High resistance paths in the output connections do not appreciably reduce the Model 261 current output accuracy if the Source is used with a low input voltage drop or feedback-type picoammeter. (Refer to paragraph 2-6 for picoammeter characteristics.) As an example, the Model 261 is used with a picoammeter with a 1-millivolt drop (Figure 3). The Source is set to  $10^{-12}$  ampere. If the leakage resistance is  $10^{12}$  ohms, the error caused by leakage,  $R_e$ , is

$$\frac{0.001 \text{ mv}}{10^{12} \text{ ohms}} = 10^{-15} \text{ ampere}$$

This is 0.1% of the source current,  $10^{-12}$  ampere. Leakage resistance of the Model 2611 Test Cable is nominally greater than  $10^{14}$  ohms.

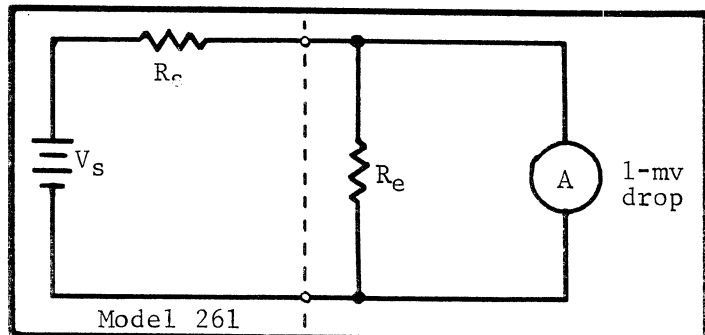

FIGURE 3. High Resistance Paths in Model 261 Output Connections. The Model 261 is shown connected to a picoammeter, A, with a 1-millivolt input drop. The Model 261 is set to  $10^{-12}$  ampere output, so the source voltage,  $V_s$ , is 1 volt and the range resistor,  $R_s$ , is  $10^{12} \Omega$ . Leakage resistance,  $R_e$ , is  $10^{12} \Omega$ .

Cause of Discrepancy in Output Current	Picoammeter Type	Ranges Affected	Paragraph Reference	Equation to Compensate for Discrepancy
Picoammeter input voltage drop more than 1/1000 of source voltage	Feedback	all	2-7	5
	Shunt-Type High-Impedance	all	2-8	6 or 8
	Shunt-Type Low-Impedance	all	2-9	8
Multiplier Switch on setting other than 1.00 (voltage coefficient)	Feedback	$10^{-9}$ to $10^{-12}$	2-10	10 or 11
	Shunt-Type High-Impedance	$10^{-9}$ to $10^{-12}$	2-10	12 or 13
	Shunt-Type Low-Impedance	$10^{-9}$ to $10^{-12}$	2-10	10 or 11
Model 261 ambient temperature differs from that stated in Calibration Certificate	all	$10^{-8}$ to $10^{-14}$	2-11	14

TABLE 1. Causes of Discrepancy in Model 261 Output Current and Correction Index. The Table summarizes compensations which may be made to correct the output current. If these are not made, the current accuracy will at least be that of the worst-case accuracy stated in paragraph 1-4. Making the correction increases accuracy.

## 2-6. INPUT VOLTAGE DROP FOR FEEDBACK AND SHUNT-TYPE PICOAMMETERS.

a. The output current accuracy is specified under the assumption that the picoammeter input voltage drop is less than 1/1000 of the Model 261 source voltage. Most feedback electrometer and chopper picoammeters will easily meet this condition. Any error caused by the picoammeter voltage drop may be eliminated by calculation if the voltage drop is known. However, only a 1% error is added if the voltage drop is 1/100 of the source voltage.

b. The general magnitude of the voltage drop is dependent upon the type of circuit the picoammeter uses. Feedback types have a low input voltage drop — approximately 1 millivolt or less. Shunt types generally have a relatively large input voltage drop (about 10 millivolts or more). However, some low-current shunt-type ammeters can be calibrated as if they were the feedback type. To help determine the type of picoammeter under calibration, a brief description of the circuits follows. Also, see Table 2.

1. Feedback-Type Picoammeter. The feedback-type picoammeter is basically an operational amplifier with a feedback resistor connected between the input and the output as shown in Figure 4. If the amplifier input current,  $I_g$ , is small compared to the input current,  $I_i$ , an expression for the amplifier output voltage,  $V_o$ , for an input current of  $I_i$  is:

$$V_o = I_i R_f \frac{k}{1-k} \quad \text{Equation 1.}$$

where  $R_f$  is the value in ohms of the feedback resistor;  
 $k$  is the amplifier gain.

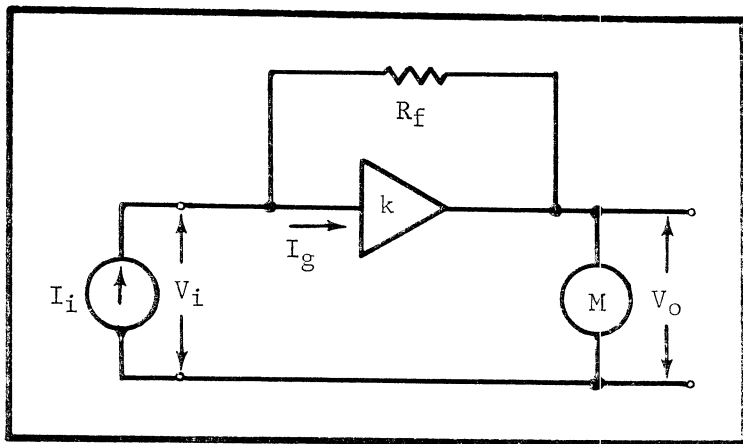

FIGURE 4. Simplified Circuit Diagram of Feedback-Type Picoammeter.  $R_f$  is the feedback resistor around the picoammeter amplifier;  $k$  is the amplifier gain.  $V_i$  is the input voltage drop and  $V_o$  is the output voltage.  $M$  is the meter.  $I_g$  is the amplifier input current. The input signal to the picoammeter is  $I_i$ .

If  $k \gg 0$ ,  $V_o \approx -I_i R_f$ .

The output voltage may be used to drive either a recorder or the meter,  $M$ . The input voltage drop,  $V_i$ , is

$$V_i = -V_o/k \quad \text{Equation 2.}$$

Typical values for the above parameters for a picoammeter are:

- Input current to picoammeter,  $I_i = 10^{-12}$  ampere
- Amplifier gain,  $k = 10^4$
- Picoammeter feedback resistor,  $R_f = 10^{12}$  ohms
- Amplifier output voltage,  $V_o = 1$  volt
- Input voltage drop,  $V_i = 100$  microvolts

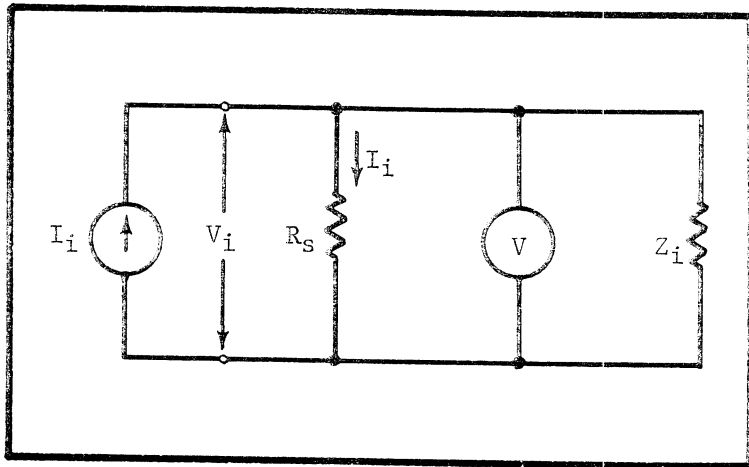

FIGURE 5. Simplified Circuit Diagram of Shunt-Type Picoammeter.  $R_s$  is the shunt resistor across the voltmeter,  $V$ .  $Z_i$  is the input impedance of the voltmeter.  $V_i$  is the picoammeter input voltage drop. The input signal to the picoammeter is  $I_i$ .

2. Shunt-Type Picoammeter. This type consists of a voltmeter,  $V$ , calibrated in amperes, which responds to the  $IR$  drop across a shunt resistor,  $R_s$ . Refer to Figure 5. The voltmeter can be one of two kinds:

a high impedance voltmeter, such as an electrometer, which has an extremely high input impedance,  $Z_i$ ;

or a low impedance voltmeter.

a) The input voltage drop,  $I_i R_s$ , of a picoammeter using a high-impedance voltmeter is usually 1 millivolt or more, due to voltmeter sensitivity limitations. Rise

time is usually slow, possibly several minutes for very low current levels. Typical values are:

Input current to picoammeter,  $I_i = 10^{-12}$  ampere  
 Picoammeter shunt resistor,  $R_s = 10^{10}$  ohms  
 Voltmeter input impedance,  $Z_i = 10^{14}$  ohms  
 Input voltage drop,  $V_i = 10$  millivolts.

b) The circuit of a shunt-type picoammeter using a low-impedance voltmeter is essentially the same as Figure 5, except a more sensitive but lower input impedance voltmeter is used. A lower input voltage drop results, but response speed and maximum current sensitivity are usually less. The voltage drop is  $I_i R_s$ . Typical values are:

Input current to picoammeter,  $I_i = 10^{-10}$  ampere  
 Picoammeter shunt resistance,  $R_s = 10^6$  ohms  
 Voltmeter input impedance,  $Z_i = 9 \times 10^7$  ohms  
 Input voltage drop,  $V_i = 100$  microvolts

#### 2-7. COMPENSATION FOR INPUT VOLTAGE DROP OF FEEDBACK-TYPE PICOAMMETERS.

a. Errors caused by picoammeter input voltage drops of 1 millivolt or less are negligible for Model 261 outputs between  $1.1 \times 10^{-4}$  and  $10^{-11}$  ampere. Following the instructions in paragraph 2-4 will bring the output current accuracy to between  $\pm 0.25\%$  and  $\pm 0.7\%$  as specified in paragraph 1-4.

b. Calculating the Error. When either the picoammeter voltage drop or input resistance is known, use either equation 3 or 4 to determine the error. Tables 3 and 4 list the

#### 1. Feedback-Type Picoammeters:

Keithley Models 409, 410, and 414 Picoammeters  
 Keithley Models 412 and 413A Log Picoammeters  
 Keithley Models 416 and 417 High-Speed Picoammeters  
 Keithley Model 418A Remote Ranging Picoammeter  
 \*Keithley Models 600A, 601, 602, 610B and 621 Electrometers (in fast mode)

#### 2. Shunt-Type Picoammeters using high-impedance voltmeters:

Keithley Models 600A, 601, 602, 610B, 621 Electrometers (normal mode)  
 Keithley Model 200B Electrometer when used with Model 2008 Decade Shunt

#### 3. Shunt-Type Picoammeters using low-impedance voltmeter:

Keithley Models 150B and 153 Microvolt-Ammeters

\* When calibrating these instruments on the low current ranges, use the normal mode and set the Multiplier Switch to 10 millivolts.

TABLE 2. Partial List of Picoammeters by Circuit Type. Generally, types 1 and 3 have low input voltage drops (1 mv and less), type 2 has a relatively high input voltage drop. Refer to paragraph 2-6.



voltage drops for Keithley current measuring instruments. Note these are maximum values; actual values will be less.

When the voltage drop is known:

$$E_{vd} = \frac{V_i \times 100}{V_s} \quad \text{Equation 3.}$$

where  $E_{vd}$  is the percent of error due to the picoammeter input voltage drop;  
 $V_i$  is the picoammeter input voltage drop in volts;  
 $V_s$  is the Model 261 source voltage, read directly in volts from the Multiplier Switch settings.

When the input resistance is known:

$$E_{vd} = \frac{R_i \times 100}{R_s} \quad \text{Equation 4.}$$

where  $R_i$  is the picoammeter input resistance in ohms;  
 $R_s$  is the Model 261 source resistance, which is the reciprocal of the Range Switch setting.

#### NOTE

Values of  $V_s$  and  $R_s$  are within  $\pm 5\%$  when read from the Model 261 Multiplier and Range Switches for all ranges except the  $10^{-5}$  ampere range, on which the values are within  $\pm 0.25\%$ . For the correction equations, this accuracy is sufficient.

c. Compensating Equation. If the voltage drop is precisely known, the actual Model 261 output current can be calculated. Equation 5 gives the output current value if the input voltage drop is the only significant source of error.

$$I_a = I_s (V_s - V_i) \quad \text{Equation 5.}$$

where  $I_a$  is the actual output current from the Model 261;  
 $I_s$  is the Range Switch setting (reciprocal of range resistor value);  
 $V_s$  is the Model 261 source voltage, read directly in volts from the Multiplier Switch setting;  
 $V_i$  is the picoammeter input voltage drop in volts.

Keithley Model	Maximum Input Voltage Drop, millivolts	Keithley Model	Maximum Input Voltage Drop, millivolts
409	1.0	414	5.0
410	5.0	416	1.0
412	5.0	417	1.0
413A	5.0	418A	1.0

TABLE 3. Maximum Voltage Drop for Keithley Picoammeters. Note the voltage drop given is the maximum at full-scale deflection; use equation 1 to figure exact values. The voltage drop is essentially constant for all ranges.

Keithley Model	Maximum Input Voltage Drop, millivolts
600A	1.0
610A, Multiplier Switch set to 1 or less	1.0
610A, Multiplier Switch set to 100 through 3	5
610B, Multiplier Switch set to .1 or less	0.01
610B, Multiplier Switch set to 10 through .3	1.0
610B, Multiplier Switch set to 100 or 30	2.0
620	1.0
621	1.0

TABLE 4. Maximum Input Voltage Drop for Keithley Electrometers. The above Electrometers, set to the fast mode, operate as feedback-type picoammeters. Note the voltage drop given is the maximum; use equation 1 to figure exact values.

#### 2-8. COMPENSATION FOR INPUT VOLTAGE DROP OF SHUNT-TYPE HIGH-IMPEDANCE PICOAMMETERS.

a. As long as the voltage drop is less than 1/1000 of the source voltage, errors due to the input voltage drop of this type picoammeter will not affect the Model 261 accuracy. Following the instructions in paragraph 2-4 will bring the accuracy of the Model 261 output current to between  $\pm 0.25\%$  and  $\pm 0.7\%$  as specified in paragraph 1-4. The chief point is setting the Multiplier Switches to higher values, so that the source voltage is 1000 times the picoammeter input voltage drop. If the meter sensitivity is adjustable, use the most sensitive range to obtain the smallest voltage drop.

#### NOTE

If the instrument can measure current on either a feedback-type or shunt-type circuit, calibrate on the feedback circuit. For example, calibrate the Keithley Model 610B Electrometer in the fast mode (feedback circuit) not the normal mode (shunt).

b. Calculating the Error. Equation 3 determines the error when the picoammeter input voltage drop is known. The voltage drop is easily found, since the meter or other read-out device indicates the voltage drop on these type picoammeters.

#### c. Compensating Equation.

1. Since the picoammeter voltage drop can be found, the Model 261 output current can be corrected. Equation 6 gives the output current value if the input voltage drop is the only significant source of error and if the voltage drop is less than 1/10 the source voltage.

$$I_a = I_s (V_s - V_i) \quad \text{Equation 6.}$$

where  $I_a$  is the actual output current from the Model 261;  
 $I_s$  is the Range Switch setting (reciprocal of range resistor value);  
 $V_s$  is the Model 261 source voltage, read directly in volts from the Multiplier Switch setting;  
 $V_i$  is the picoammeter input voltage drop in volts, read from the meter.

Using this correction, accuracy is  $\pm 0.5\%$  +(Model 261 accuracy). This error results from the factory calibration method used for the Model 261 that adjusts the source voltage from that indicated to match the range resistor used. (See paragraph 6-6.)

2. For greater accuracy or if the input drop is more than 0.1 times the source voltage, use equation 8 to compensate for the error. The following equation is based on the calibration procedures.

$$V'_S = V_S \left( \frac{R'_S}{1/I_S} \right) = V_S R'_S I_S \quad \text{Equation 7.}$$

where  $V'_S$  is the actual source voltage;  
 $V_S$  is the Model 261 source voltage, read directly in volts from the Multiplier Switch setting;  
 $R'_S$  is the actual source resistance — from the Calibration Certificate supplied with the Model 261;  
 $I_S$  is the Model 261 Range Switch setting (reciprocal of range resistor value).

Using equation 7 in equation 6 and substituting  $V'_S$  for  $V_S$ ,

$$I_a = I_S (I_S V_S R'_S - V_i) \quad \text{Equation 8.}$$

where  $I_a$  is the actual output current from the Model 261;  
 $V_i$  is the picoammeter input voltage drop in volts read from the meter.

Using equation 8 completely compensates for the error due to the input voltage drop.

#### 2-9. COMPENSATION FOR INPUT VOLTAGE DROP OF SHUNT-TYPE LOW-IMPEDANCE PICOAMMETERS.

a. For the most part, the voltage drop for this type picoammeter is about the equivalent of that of the feedback-type picoammeter — 1 millivolt or less. Following the directions in paragraph 2-4 will assure Model 261 output currents within the specified accuracy.

b. To compensate for output current differences caused by input voltage drops, use equation 8. This calculation will be precise, since the voltage drop is read directly from the picoammeter meter.

#### 2-10. COMPENSATION FOR VOLTAGE COEFFICIENT.

a. On Range Switch settings from  $10^{-9}$  to  $10^{-12}$ , inaccuracies caused by the voltage coefficient of high-megohm resistors become significant in certain cases. The voltage coefficient does not affect current output when the Range Switch is set to  $10^{-8}$  or higher. When the Multiplier Switches are set to 1.00, no discrepancy is caused on any range. Other Multiplier Switch settings on the  $10^{-9}$  to  $10^{-12}$  ranges, however, will introduce some error. Note that the output current accuracy will be at least that listed in the second column — worst-case accuracy — of the Accuracy Specification in paragraph 1-4. The specified accuracy includes the effects of the voltage coefficient for the  $10^{-13}$  and  $10^{-14}$  ampere ranges.

Range Switch Setting	Multiplier Switch Setting (source voltage in volts)	Voltage Coefficient (add to output current) %/volt
10 <sup>-12</sup>	1.00 to 3.00	+0.4
10 <sup>-12</sup>	3.01 to 11.00	+0.02
10 <sup>-11</sup>	1.00 to 3.00	+0.15
10 <sup>-11</sup>	3.01 to 11.00	+0.04
10 <sup>-10</sup>	1.00 to 3.00	+0.1
10 <sup>-10</sup>	3.01 to 11.00	+0.015
10 <sup>-9</sup>	1.00 to 3.00	+0.1
10 <sup>-9</sup>	3.01 to 11.00	+0.01

TABLE 5. Voltage Coefficients for Various Range Switch Settings. The effect on the output current caused by the range resistor voltage coefficient is not significant for other-Range Switch settings. The accuracy of the voltage coefficients stated is ±10%.

b. Compensating Equation: Feedback-Type and Shunt-Type Low-Impedance Picoammeters. The effect of the high-megohm voltage coefficient on the Model 261 current output can be calculated using equation 9. This gives the current value measured by the picoammeter if the effect of voltage coefficient is the only significant source of error.

$$I_a = I_s \left[ \frac{V_s}{1 - .01 VC (V_s - 1)} \right] \quad \text{Equation 9.}$$

where  $I_a$  is the actual or compensated Model 261 output current;  
 $I_s$  is the Range Switch setting (reciprocal of range resistor value);  
 $V_s$  is the source voltage in volts, read directly from the Multiplier Switches;  
 $VC$  is the voltage coefficient for the settings of the Range Switch and the Multiplier Switches (Table 5). It is multiplied by .01, since the Table value is a percent.

Using the Taylor Series Expansion\* for Equation 9:

$$I_a = V_s I_s [1 + .01 VC (V_s - 1)] \quad \text{Equation 10.}$$

For Multiplier Switch setting more than 3.00, make two corrections — from 1 to 3 volts and from 3 to N volts. See equation 11.

$$I_a = V_s I_s [1 + (.01 \times VC_{1-3} \times 2) + .01 \times VC_{3-11} (V_s - 3)] \quad \text{Equation 11.}$$

$VC_{1-3}$  is the voltage coefficient from 1 to 3 volts;  
 $VC_{3-11}$  is the voltage coefficient from 3 to 11 volts.

\* Taylor Series Expansion:  $\frac{a}{1-x} \approx a(1+x)$  for  $x \ll 1$

Example 1: The Model 261 is set to  $3.00 \times 10^{-12}$  ampere. Using equation 10, the actual current output is:

$$I_a = 3.00 \times 10^{-12} [1 + .01 \times .4 (3.00-1)]$$

$$I_a = 3.024 \times 10^{-12} \text{ ampere.}$$

This value differs from the dial value slightly:

$$\frac{0.024}{3.00} = 0.008 \text{ or } 0.8\%$$

Without making this correction, the accuracy would be 0.7% (accuracy at  $10^{-12}$ ) plus 0.8% or 1.5%. This is less than the specified worst-case accuracy of  $\pm 1.6\%$ .

Example 2: The Model 261 is set to  $5.00 \times 10^{-12}$  ampere. Using equation 11, the actual current output is:

$$I_a = 5.00 \times 10^{-12} [1 + (.01 \times .4 \times 2) + .01 \times .02 (5.00-3.00)]$$

$$I_a = 5.042 \times 10^{-12} \text{ ampere.}$$

This value differs from the dial value slightly: 0.81%. Without making this correction, the accuracy would be 1.51%, which is under the specified worst-case accuracy of  $\pm 1.6\%$ .

c. Compensating Equations: Shunt-Type High-Impedance Picoammeters. The calculation is essentially the same as described in the previous subparagraph. The difference is a correction for the source voltage in equations 10 and 11. If the difference between the input voltage drop and the source voltage is less than 3, equation 10 becomes

$$I_a = (V_s - V_i) I_s [1 + .01 VC (V_s - V_i - 1)] \quad \text{Equation 12.}$$

where  $I_a$  is the actual or compensated Model 261 output current;

$V_s$  is the source voltage in volts, read directly from the Multiplier Switches;

$V_i$  is the picoammeter input voltage drop in volts;

$I_s$  is the Range Switch setting (reciprocal of the range resistor value);

VC is the voltage coefficient for the settings of the Range Switch and the Multiplier Switches (Table 5). It is multiplied by .01, since the Table value is a percent.

If the difference between the input voltage drop and the source voltage is more than 3, equation 11 becomes

$$I_a = (V_s - V_i) I_s [1 + (.01 \times VC_{1-3} \times 2) + .01 \times VC_{3-11} (V_s - V_i - 3)] \quad \text{Equation 13.}$$

where  $VC_{1-3}$  is the voltage coefficient from 1 to 3 volts;

$VC_{3-11}$  is the voltage coefficient from 3 to 11 volts.

## 2-11. COMPENSATION FOR TEMPERATURE COEFFICIENT.

a. When the Model 261 is used on Range Switch settings above  $10^{-8}$  or at the temperature listed on the Calibration Certificate, the room temperature will not affect the output current. For Range Switch settings from  $10^{-9}$  to  $10^{-12}$ , the value of the range resistor decreases as the temperature increases. Therefore, the Model 261 current output will be more than the value desired.

b. The Model 261 is calibrated at a specified temperature  $\pm 0.5^\circ\text{C}$ , which is stated on the Calibration Certificate, for the  $10^{-9}$  to  $10^{-12}$  ranges. The Certificate also lists the temperature coefficients by range. These range from  $-0.06\%/^\circ\text{C}$  to  $0.15\%/^\circ\text{C}$  for the  $10^{-9}$  through  $10^{-12}$  ampere ranges respectively.

## NOTE

The stated temperature coefficient holds for an ambient temperature variation of  $23^\circ\text{C} \pm 5^\circ\text{C}$ .

c. Compensating Equation. The effect of temperature differences on the Model 261 current output can be calculated using equation 14. This gives the output current value if the temperature effect is the only significant source of error.

$$I_a = I_s \left[ \frac{1}{1 - (T_2 - T_1) \frac{tc}{100}} \right] \approx I_s [i + (T_2 - T_1) \times .01 \times tc] \text{ Equation 14.}$$

where  $I_a$  is the actual or compensated Model 261 current output;  
 $I_s$  is the indicated current output (Range Switch setting times the Multiplier Switch settings);  
 $T_2$  is the room temperature in  $^\circ\text{C}$ ;  
 $T_1$  is the calibration temperature in  $^\circ\text{C}$ ;  
 $tc$  is the temperature coefficient of the range resistor in  $\%/^\circ\text{C}$  given on the Calibration Certificate.

### SECTION 3. APPLICATIONS

3-1. GENERAL. This Section discusses ways of using the Model 261 Picoampere Source. Three applications are particularly well suited for the instrument: current suppression, galvanometric measurements and ohmmeter calibration. These do not exhaust the possibilities of using the Model 261; instead, they illustrate the techniques used for the most common applications other than in calibrating picoammeters.

#### 3-2. CURRENT SUPPRESSION.

a. The Model 261 can be used to buckout or suppress steady background currents so that a picoammeter can measure small variations in the signal. For instance, using this system enables a picoammeter to observe small fluctuations in a phototube output, while the Model 261 suppresses the dark currents.

b. Because of its wide use, the Keithley Model 610B Electrometer is used to illustrate the application. With the Models 261 and 610B, suppression up to 1000 times full scale is possible. Suppression up to at least 100 times is possible with most picoammeters.

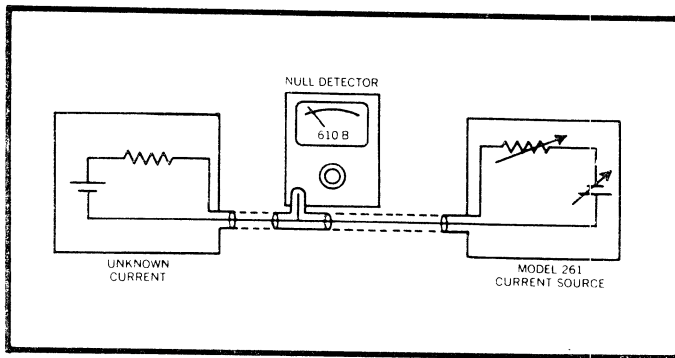

FIGURE 6. Circuit Diagram for Current Suppression. Connect the coaxial T fitting directly to the Model 610B INPUT receptacle. Use the Model 2611 Cable for connecting instruments.

c. Connect the Models 261 and 610B to the unknown current as shown in Figure 6. Make sure the connections are well made; use the Model 2611 Test Cable or other coaxial cable. Refer to paragraph 2-5.

d. Operate the Model 261 as previously described in paragraphs 2-3 and 2-4. Set the Model 610B FEEDBACK Switch to FAST; this makes the Electrometer a feedback-type picoammeter. Set the Model 261 POLARITY Switch to the polarity opposite that of the unknown current. Set the current output to a value as near as possible to that of the current to be suppressed. Set the Model 610B to the least sensitive ampere range; gradually increase sensitivity until a null is reached. Keep its Multiplier Switch on 1.

e. Set both the Model 261 and 610B Range Switches to the same setting. If the Electrometer is set to a lower range, the Model 261 source resistance will divide the Model 610B feedback. This will impair the Electrometer's zero stability. Switch the Multiplier Switch gradually from 1 to .001. In this last setting, the Model 610B current sensitivity is 1000 times the unknown current.

f. The procedures with other instruments are the same. Check the picoammeter's specifications to find any circuit limitations. Set the picoammeter to the best sensitivity possible.

## 3-3. GALVANOMETRIC MEASUREMENTS.

a. In this application, the Model 261 bucks out the unknown current and a picoammeter serves as a null detector. Currents as low as  $10^{-12}$  ampere can be measured to  $\pm 0.7\%$ , using the Keithley Model 610B Electrometer as a null detector.

b. Follow the same procedures for this measurement as given in paragraph 3-2. In use, galvanometric measurements are a special case of current suppression.

## 3-4. OHMMETER CALIBRATION.

a. The Model 261 contains calibrated resistance standards, which make it very useful for checking high resistance measuring instruments. The Range Switch indicates the reciprocal of the nominal value of the range resistor. The exact resistor value is on the Calibration Certificate supplied with each Source.

## b. Procedures.

1. Set the Model 261 POLARITY Switch to OFF and the Multiplier Switches to 0.00. Set the Range Switch to the reciprocal of the ohms range to be checked. Connect the ohmmeter to the Source OUTPUT Receptacle using coaxial cable. Follow the hookup procedures outlined in paragraph 2-5.

2. Carefully shield connections above  $10^8$  ohms. Use guarded connections for resistances  $10^9$  ohms and more. See Figure 8. A guarded connection to the range resistor will eliminate the shunting effect of cable and connector resistance. For example, using the  $10^{10}$  ohm range, a  $10^{12}$  ohm leakage resistance will add an error of 1%. To make the connection, set the CAL-OPERATE Switch (S101, Figure 10) to CAL. Remove the link between the GND and COM Terminals of the Source. The outer shell of the OUTPUT Receptacle is the guard and the G Binding Post beside it is connected to the low side of the range resistor.

3. Record the ohmmeter measurement and compare it to the values on the Model 261 Calibration Certificate. The  $10^{12}$ ,  $10^{11}$ ,  $10^{10}$  and  $10^9$  ohm resistors decrease in value at the rate of approximately 0.15% per month after factory calibration. The  $10^8$  ohm resistor increases in value at the same rate. Determine a more exact rate by interpolating the resistance change on the Calibration Certificate for the three months prior to shipment.

c. The voltage developed by the ohmmeter across the  $10^{12}$ ,  $10^{11}$ ,  $10^{10}$  and  $10^9$  ohm resistors will have some effect on the resistance value due to the voltage coefficient. Refer to Table 5 for the voltage coefficients by ranges, and the effect can be calculated. The Calibration Certificate lists the potential used in measuring the range resistors.

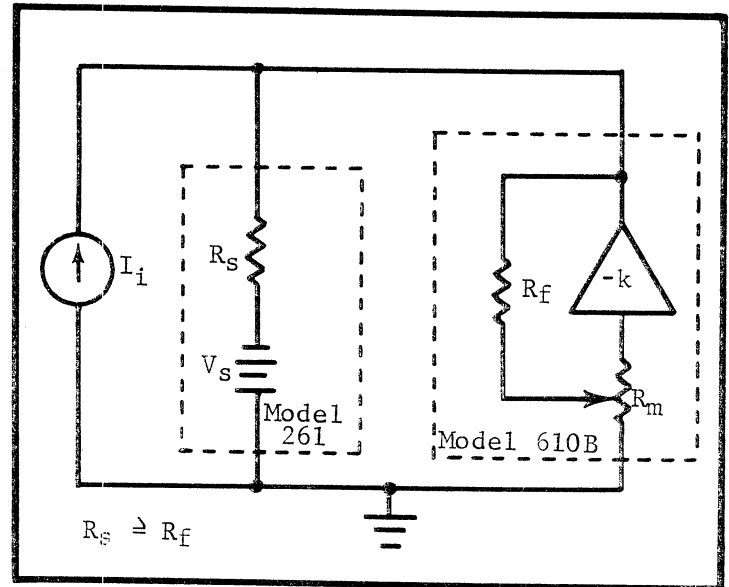

FIGURE 7. Circuit for Galvanometric Measurements.  $R_s$  is the Model 261 source resistance;  $V_s$ , the source voltage.  $R_f$  is the picoammeter feedback resistor;  $k$ , the amplifier gain;  $R_m$ , the Multiplier Switch,  $I_i$  is the unknown current.



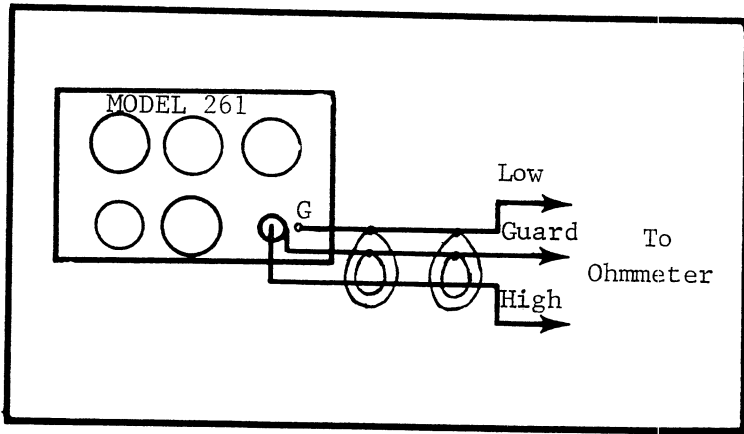

FIGURE 8. Guarded Circuit for Ohmmeter Calibration. This circuit is recommended for resistances of  $10^9$  ohms and more.



## SECTION 4. CIRCUIT DESCRIPTION

### 4-1. GENERAL.

- a. The Keithley Model 261 Picoampere Source is basically a precision variable voltage source in series with a selectable range resistor. The circuit provides currents from  $10^{-14}$  to  $1.1 \times 10^{-4}$  ampere when used with a low input drop picoammeter.
- b. The variable voltage source uses a stable ( $\pm 0.05\%/yr$ ) zener regulated solid-state voltage supply and a 3-dial Kelvin-Varley divider which has  $\pm 0.1\%$  accuracy. The Multiplier Switches, S103 to S105, contain the divider resistors.
- c. The Range Switch also programs the voltage supply output for each individual current range to provide a means of calibration.

#### NOTE

Refer to Schematic Diagram 18323E for circuit designations.

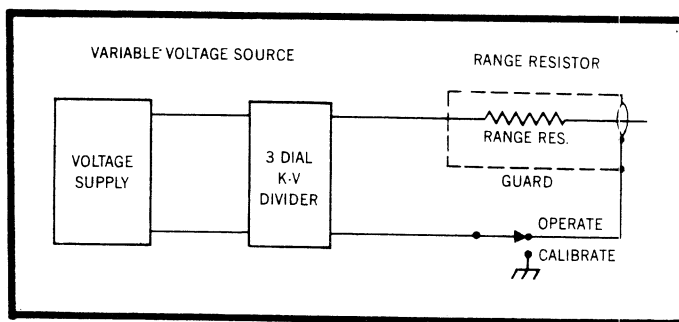

FIGURE 9. Simplified Model 261 Block Diagram.

### 4-2. RANGE RESISTORS.

- a. The range resistors, R101 through R108, are mounted on a specially designed rotary switch, Range Switch S102, using Teflon insulation, and silver and gold-plated contacts. The  $10^{-5}$  ampere range resistor, R101, is a 0.02% wirewound resistor. 1% carbon film resistors, R102 to R104, are used on the  $10^{-6}$  to  $10^{-8}$  ranges. The most sensitive ranges use glass sealed high-megohm resistors. The high-megohm resistors are carefully selected after a 3-month stability test. Capacitor C101 and

resistors R109, R110 and R111 form a damping network to compensate for capacity across the high-megohm resistors, R106 to R108. The network eliminates high current transients when the Picoampere Source is turned on. The voltage source connects through one deck of switch S102 to the range calibration controls, R113 through R119.

- b. The Range Switch, OUTPUT Receptacle J104 and the range resistors are encased in a floating shield which is normally connected to the low side of the output. The shield is also connected as a guard for resistance measurements or for calibration when Switch S101 is in the CAL position.

4-3. KELVIN-VARLEY DIVIDER. The Kelvin-Varley divider uses 0.1% precision wirewound resistors, R120 through R152, to divide the 11.0 volts from the voltage supply to the value selected with the Multiplier Switches.

### 4-4. VOLTAGE SUPPLY.

- a. The voltage supply operates from either 117 or 234 volts, 50-1000 cps to furnish a stable 11.0 volts with 0.01% line stability for a 10% change in line voltage.

- b. The power transformer, T201, is specially constructed and shielded to provide better than  $10^9$  ohm insulation shunted by 0.001-microfarad isolation from the secondary to ground or line.
- c. The 15-volt rms output from the power transformer, T201, is full-wave rectified by diodes D202 and D203, and then is filtered by capacitor C202 to approximately 17 volts dc.
- d. To obtain a stable, accurate voltage, the output of the series transistor regulator, Q202, is regulated by comparing a sample voltage from dividers R211, R210, R201 and one of the resistors R112 to R119 to zener diode reference, D207. If a voltage difference exists, it is amplified by a differential amplifier consisting of transistors Q204 and Q205. The signal is further amplified by transistor Q203. The output of Q203 is applied to the Darlington pair, Q201 and Q202, to nullify input and load variations. Capacitor C203 prevents high-frequency oscillations. The 11-volt regulator output is applied to the Kelvin-Varley divider through the POLARITY Switch, S106.
- e. Transistor Q203 operates at a high gain by connecting its collector load to a negative regulated supply. The circuit permits linear operation of transistor Q202 with widely varying input voltages. To supply Q203, one side of the secondary of T201 is half-wave rectified and filtered by diode D201 and capacitor C201 respectively. Resistor R202 and zener diode D204 regulate this voltage to a stable -6 volts, referred to the collector of transistor Q202.
- f. Resistors R204 and R205 and diode D205 provide current overload protection. Excessive current drawn from the power supply causes an increased voltage drop across resistor R204, which forward biases diode D205, thus preventing the collector of transistor Q203 from going more negative. Since the collector voltage cannot rise, further amplification is prevented and, therefore, further current increase is prevented.

## SECTION 5. SERVICING

5-1. GENERAL. Section 5 contains the maintenance and troubleshooting procedures for the Model 261 Picoampere Source. It is recommended that these procedures be followed as closely as possible to maintain the accuracy of the instrument.

### 5-2. SERVICING SCHEDULE.

a. The Model 261 requires no periodic maintenance beyond the normal care required of high-quality electronic equipment. No part should need replacement under ordinary use except the pilot lamp or the fuse.

b. Check the value of the high-megohm resistors, R104 through R108, every three months. If necessary, recalibrate the Source to assure specified accuracy; see Section 6. Either the user or Keithley Instruments, Inc., can perform the calibration.

### 5-3. PARTS REPLACEMENT.

a. The Replaceable Parts List in Section 8 describes the electrical components of the Picoampere Source. Replace components only as necessary. Use only reliable replacements which meet the specifications.

b. The range resistors, R104 through R108 (Figure 12), are specially selected and aged to assure the specified Model 261 accuracy for three months. In normal use they do not need replacement. If it is necessary, however, order them from Keithley Instruments, Inc. only. Use the Keithley Part Number given in the Replaceable Parts List. In an emergency, these resistors may be obtained from another distributor, but their stability cannot be guaranteed. In either case, recalibrate the Model 261 after replacing any range resistor.

#### NOTE

When replacing the range resistors, R104 through R108, do not touch the glass body. Contamination of the specially coated glass insulation will occur, and leakage will result.

### 5-4. TROUBLESHOOTING.

a. The procedures which follow give instructions for repairing troubles which might occur in the Model 261. Use the procedures outlined and use only specified replacement parts. Table 6 lists equipment recommended for troubleshooting. If the trouble cannot be readily located or repaired, Keithley Instruments, Inc., can service the instrument at its complete service facilities. Contact your nearest representative.

Instrument	Use
Keithley Model 153 or another dc voltmeter, with minimum 100-megohm input resistance, 10% accuracy, range from one to 300 volts.	Circuit checking.

TABLE 6. Equipment Recommended for Model 261 Troubleshooting. Use these instruments or their equivalent.

Difficulty	Probable Cause	Solution
No current output on all ranges	Defective voltage supply	Check Q202 and D208 for "open"
	Defective Kelvin-Varley divider	Check S103 through S106; check R120 through R152
No current output on one range	Defective range resistor	Check corresponding range resistor for open circuit
Output too high on all ranges	Defective voltage supply	Check Q202 for short
Output too high on one range	Defective range resistor	Check corresponding range resistor

TABLE 7. Model 261 Troubleshooting.

b. Table 7 contains the more common troubles which might occur. If the repairs indicated in the Table do not clear up the trouble, find the difficulty through a circuit-by-circuit check, such as given in paragraph 5-5. Refer to the circuit description in Section 4 to find the more critical components and to determine their function in the circuit. The complete circuit schematic diagram, 18323E, is found in Section 8.

#### 5-5. PROCEDURES TO GUIDE TROUBLESHOOTING.

a. If the instrument will not operate, check the fuse, line cord and power source. If these are all found satisfactory, use the following procedures to isolate the trouble.

b. The schematic diagram indicates all the transistor terminal voltages referenced to J202. Check the Notes on the diagram for the settings used.

#### c. Voltage Supply.

1. Set the POLARITY Switch to + and connect the dc voltmeter between the black test jack, J202, and the emitter of transistor Q202 (Figure 11). The voltage should be -11.6 volts.

2. If the voltage is not -11.6 volts, measure the voltage at the collector of transistor Q202. It should be 17 volts  $\pm 20\%$ . Presence of this voltage indicates the regulator circuitry is not operating or transistor Q202 is defective.

3. Measure the voltage at the anode of diode D204 (Figure 11). It should be -17.1 volts  $\pm 10\%$ . If this bootstrap voltage is not sufficient, transistor Q203 (Figure 11) will not operate and transistors Q201 and Q202 will be cutoff.

4. Check the reference amplifier and amplifier stage using the schematic voltage values as a guide.

## SECTION 6. CALIBRATION

### 6-1. GENERAL.

a. The following procedures are recommended for calibrating and adjusting the Model 261. Use the equipment recommended in Table 8. If proper facilities are not available or if difficulty is encountered, contact Keithley Instruments, Inc., or its representative to arrange for factory calibration.

b. Calibration is done in three steps. The voltage supply is adjusted to furnish an accurate potential (paragraphs 6-3 and 6-4). The range resistors are measured with a megohm bridge to verify their values (paragraph 6-5). Then, the supply voltage is set on each range with separate internal adjustments so that the output current corresponds to the dial reading (paragraph 6-6). Calibrate in this order.

c. If the Model 261 is not within specifications after the calibration and adjustments, follow the troubleshooting procedures or contact Keithley Instruments, Inc., or its nearest representative.

#### NOTE

Certification traceable to the National Bureau of Standards is available for the Model 261 from Keithley Instruments, Inc.

6-2. CALIBRATION SCHEDULE. Calibrate the Model 261 every three months to adjust for even small changes in the value of components. Also, recalibrate after replacing any transistors, Kelvin-Varley divider resistors or range resistors.

### 6-3. VOLTAGE SUPPLY ADJUSTMENT.

a. This adjustment sets the potential applied by the voltage supply to the Kelvin-Varley dividers. Normally, checking the output value is sufficient, unless components of the supply are replaced.

#### b. Procedures.

1. Connect the Model 662 Differential Voltmeter across the Kelvin-Varley divider. Connect the positive lead to the grey-white wire on the X.01 Switch, S103, and the negative lead to the black-blue wire on the X1 Switch, S105 (Figure 10).

Instrument	Use
Electro Scientific Industries Model 242A Precision Resistance Measuring System	Verify range resistor value for 10 <sup>-5</sup> ampere range
Keithley Instruments Model 515 Megohm Bridge and Model 2612 Calibration Cable	Verify range resistor values for 10 <sup>-6</sup> to 10 <sup>-12</sup> ampere ranges.
Keithley Instruments Model 662 Differential Voltmeter. Must read 10 volts ±5 mv.	Adjust voltage supply, range potentiometers and check potential across Kelvin-Varley dividers

TABLE 8. Equipment Recommended for Model 261 Calibration. Use these instruments or their equivalents.

Control	Circuit Desig.	Fig. Ref.	Refer to Paragraph
10 <sup>-6</sup> Range Calibration	R113	10	6-6
10 <sup>-7</sup> Range Calibration	R114	10	6-6
10 <sup>-8</sup> Range Calibration	R115	10	6-6
10 <sup>-9</sup> Range Calibration	R116	10	6-6
10 <sup>-10</sup> Range Calibration	R117	10	6-6
10 <sup>-11</sup> Range Calibration	R118	10	6-6
10 <sup>-12</sup> Range Calibration	R119	10	6-6
10 <sup>-5</sup> Range Calibration	R210	10	6-3, 6-6
Calibrate-Operate Control	S101	10	6-5, 6-6 3-4

TABLE 9. Model 261 Internal Controls. The Table lists all internal controls, the figure picturing the location, and the paragraph describing the adjustment.

2. Set the CAL-OPERATE Switch S201 (Figure 10) to OPERATE. Set the Model 261 Range Switch to 10<sup>-5</sup>; set the POLARITY Switch to +. Set the Multiplier Switches to 10.00.

3. The Model 662 should read 10 volts  $\pm 5$  millivolts. If necessary, adjust potentiometer R210 (Figure 10) for this output.

6-4. VERIFICATION OF MULTIPLIER SWITCH SETTINGS. This verification checks the divided potential from the voltage supply. Keep the Model 662 connected as in paragraph 6-3. Set the Multiplier Switches to 0.00. Then switch each Multiplier Switch through every setting, keeping the other two Switches at 0. The potential for each setting is listed in Table 10. Readings must be within the tolerance for the setting.

Multiplier Switch Setting	Voltage Reading	Tolerance	Multiplier Switch Setting	Voltage Reading	Tolerance
10.00	10 volts	$\pm 5$ mv	0.40	0.4 volt	$\pm 0.84$ mv
9.00	9 volts	$\pm 9$ mv	0.30	0.3 volt	$\pm 0.64$ mv
8.00	8 volts	$\pm 8$ mv	0.20	0.2 volt	$\pm 0.44$ mv
7.00	7 volts	$\pm 7$ mv	0.10	0.1 volt	$\pm 0.24$ mv
6.00	6 volts	$\pm 6$ mv	0.00	0.0 volt	$\pm 40$ $\mu$ v
5.00	5 volts	$\pm 5$ mv	0.09	0.09 volt	$\pm 310$ $\mu$ v
4.00	4 volts	$\pm 4$ mv	0.08	0.08 volt	$\pm 280$ $\mu$ v
3.00	3 volts	$\pm 3$ mv	0.07	0.07 volt	$\pm 250$ $\mu$ v
2.00	2 volts	$\pm 2$ mv	0.06	0.06 volt	$\pm 220$ $\mu$ v
1.00	1 volt	$\pm 1$ mv	0.05	0.05 volt	$\pm 190$ $\mu$ v
0.00	0 volt	$\pm 40$ $\mu$ v			
0.90	0.9 volt	$\pm 1.84$ mv	0.04	0.04 volt	$\pm 160$ $\mu$ v
0.80	0.8 volt	$\pm 1.64$ mv	0.03	0.03 volt	$\pm 130$ $\mu$ v
0.70	0.7 volt	$\pm 1.44$ mv	0.02	0.02 volt	$\pm 100$ $\mu$ v
0.60	0.6 volt	$\pm 1.24$ mv	0.01	0.01 volt	$\pm 100$ $\mu$ v
0.50	0.5 volt	$\pm 1.04$ mv	0.00	0.00 volt	$\pm 100$ $\mu$ v

TABLE 10. Voltage for Multiplier Switch Settings. Refer to paragraph 6-4 for verification procedures. The 40 microvolts at 0.00 is the residual voltage.



## 6-5. VERIFICATION OF HIGH MEGOHM RESISTORS.

a. The following procedure outlines the method used at factory calibration to measure the value of the high-megohm range resistors. Keithley Instruments, Inc., specifies the Picoampere Source will be within specifications for three months after it has calibrated the instrument. The inherent drift of the high megohm resistors sets the time limit. If the user performs the calibration, it is very important that he use the finest procedures followed by Standards Laboratories.

## b. Procedures.

1. Disconnect the Model 261 power cord from the power source; remove the link from the COM Binding Post on the rear panel. Set the CAL-OPERATE Switch (Figure 10) to CAL. The CAL-OPERATE Switch is a 2-position slide switch. In CAL position, the low side of the range resistor is connected to chassis ground, and the low side of the OUTPUT Receptacle (threaded shell) is connected as a guard between the high side of the output and ground.
2. Calibrate the Keithley Model 515 High Megohm Bridge per its instruction manual.
3. Connect the Model 261 OUTPUT Receptacle to the Model 515 using the Model 261<sup>2</sup> Calibration Cable. Use the Model 515 for all ranges except  $10^{-5}$  ampere. For this range, use the ESI Model 242A since it has the necessary accuracy at this resistance.

## NOTE

Make sure the Cable will not be moved or allowed to vibrate during the tests.

4. Set the Bridge controls to the values listed in Table 11. Record the values measured to use for range calibration (paragraph 6-6). Table 11 lists the accuracy obtainable for the measurement.

Model 261 Range Switch Setting	Model 261 Resistance Value (ohms)	Bridge Setting	Bridge Potential Setting (volts)	Accuracy of Measurement
* $10^{-5}$	* $10^5$ $\pm 0.02\%$	* $1 \times 10^5$	* 0.9	$\pm 0.02\%$
$10^{-6}$	$10^6$ $\pm 1\%$	$10 \times 10^5$	10	$\pm 0.1\%$
$10^{-7}$	$10^7$ $\pm 1\%$	$10 \times 10^6$	10	$\pm 0.1\%$
$10^{-8}$	$10^8$ $\pm 2\%$	$10 \times 10^7$	10	$\pm 0.5\%$
$10^{-9}$	$10^9$ $\pm 5\%$	$10 \times 10^8$	1.1	$\pm 0.5\%$
$10^{-10}$	$10^{10}$ $\pm 5\%$	$10 \times 10^9$	1.1	$\pm 0.5\%$
$10^{-11}$	$10^{11}$ $\pm 5\%$	$10 \times 10^{10}$	1.1	$\pm 0.5\%$
$10^{-12}$	$10^{12}$ $\pm 5\%$	$10 \times 10^{11}$	1.1	$\pm 0.5\%$

TABLE 11. Settings for Range Resistor Verification. Refer to paragraph 6-5 for procedures. The Keithley Model 515 is used for all ranges except the  $10^{-5}$  ampere (\*), for which the ESI 242A is used. Bridge potential settings are nominal. Actual potential is on the Calibration Certificate.

6-6. RANGE CALIBRATION.

a. Calibrate the ranges after performing the previous procedures in this Section, paragraphs 6-3 to 6-5. Range calibration is based on all other adjustments and verifications being complete and accurate. Perform this calibration any time the voltage supply is adjusted or if any Kelvin-Varley resistor or range resistor is replaced.

b. Procedures. The basis of this calibration is  $I = V/R$ . The range potential is adjusted to correspond to the exact range resistor value, so that the current produced is equal to one times the range.

1. Set the Model 261 CAL-OPERATE Switch to OPERATE. Connect the Picoampere Source to the proper line source. Connect the Model 662 Differential Voltmeter across the Kelvin-Varley divider. Connect the positive lead to the grey-white wire on the X.01 Switch, S103, and the negative lead to the black-blue wire on the X1 Switch, S105 (Figure 10).

2. Set the Model 261 controls to:

POLARITY Switch	+
Range Switch	$10^{-5}$
Multiplier Switches	10.00

3. Adjust the  $10^{-5}$  CAL Potentiometer, R210 (Figure 10), for 10.012 volts  $\pm 5$  millivolts when read on the Model 662. Setting the voltage 12 millivolts high compensates for any loading errors on the  $10^{-5}$  ampere range.

4. Set the Multiplier Dials to 1.00; switch the Model 261 through all ranges. Use the internal potentiometer for each range to set the range potential to R volt  $\pm$  the tolerance listed in Table 12. R is the exact resistor value (paragraph 6-5).

Example: The  $10^{-11}$  range resistor is measured (paragraph 6-5) and its value is  $1.019 \times 10^{11}$  ohms. The range potential is now adjusted when the Range Switch is set to  $10^{-11}$  and the Multiplier Switches to 1.00. Using Table 12, potentiometer R118 is set so the Differential Voltmeter reads 1.019 volts  $\pm 0.5$  millivolts.

Multiplier Switch Setting	Range Switch Setting	Set Range Potentiometer	To Exact Value of Range Resistor on	Tolerance
1.00	$10^{-6}$	R113	$10^{-6}$ Range	$\pm 0.5$ mv
1.00	$10^{-7}$	R114	$10^{-7}$ Range	$\pm 0.5$ mv
1.00	$10^{-8}$	R115	$10^{-8}$ Range	$\pm 0.5$ mv
1.00	$10^{-9}$	R116	$10^{-9}$ Range	$\pm 0.5$ mv
1.00	$10^{-10}$	R117	$10^{-10}$ Range	$\pm 0.5$ mv
1.00	$10^{-11}$	R118	$10^{-11}$ Range	$\pm 0.5$ mv
1.00	$10^{-12}$	R119	$10^{-12}$ Range	$\pm 0.5$ mv

TABLE 12. Range Calibration. Refer to paragraph 6-6. When the Model 261 Multiplier and Range Switches are set as above, adjust the corresponding potentiometer to the range resistor value recorded in paragraph 6-5.

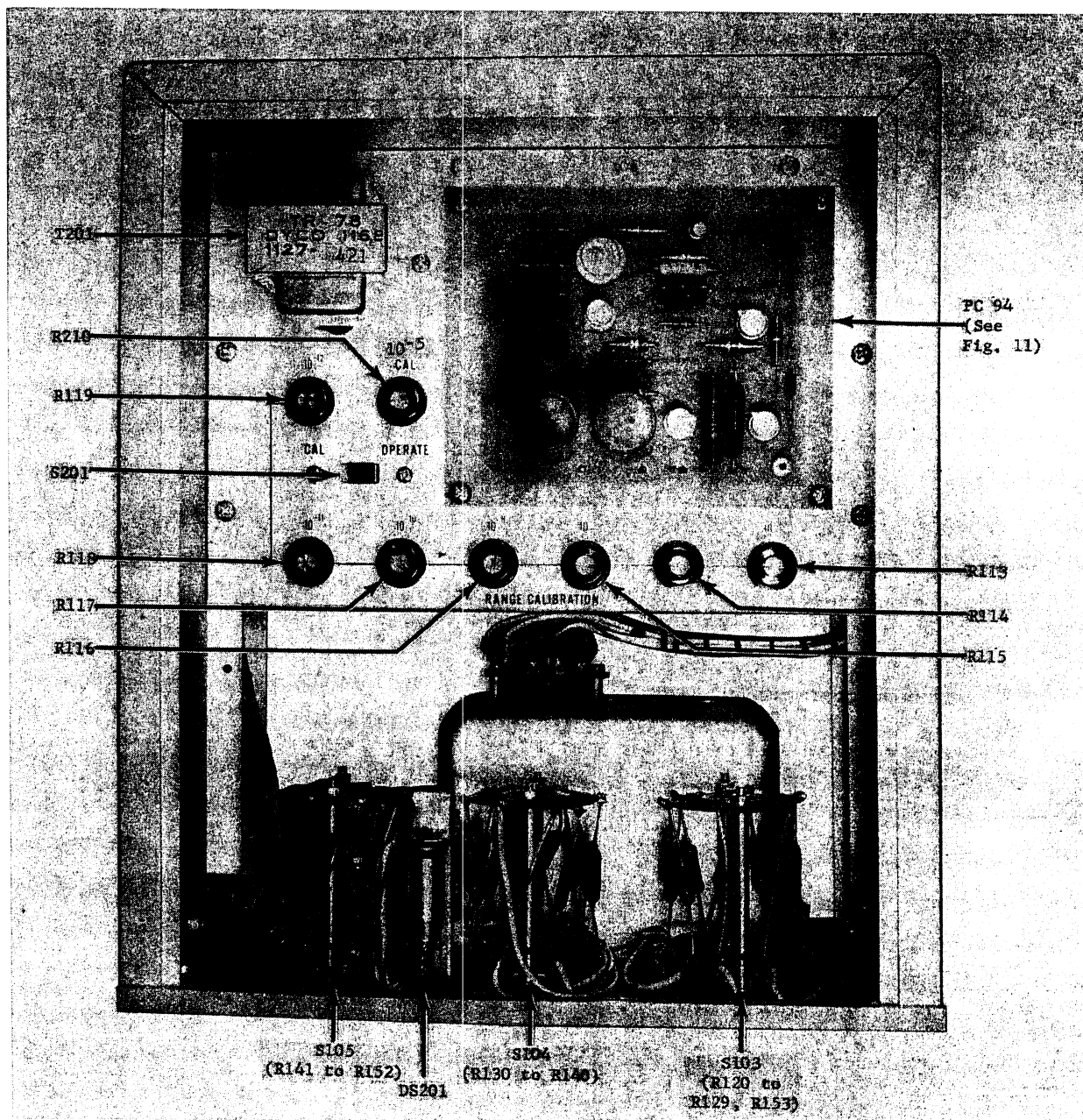

FIGURE 10. Top View of Model 261 Chassis. The front panel is along the bottom of the photograph. Location of components is shown. Refer to Replaceable Parts List for circuit designations.

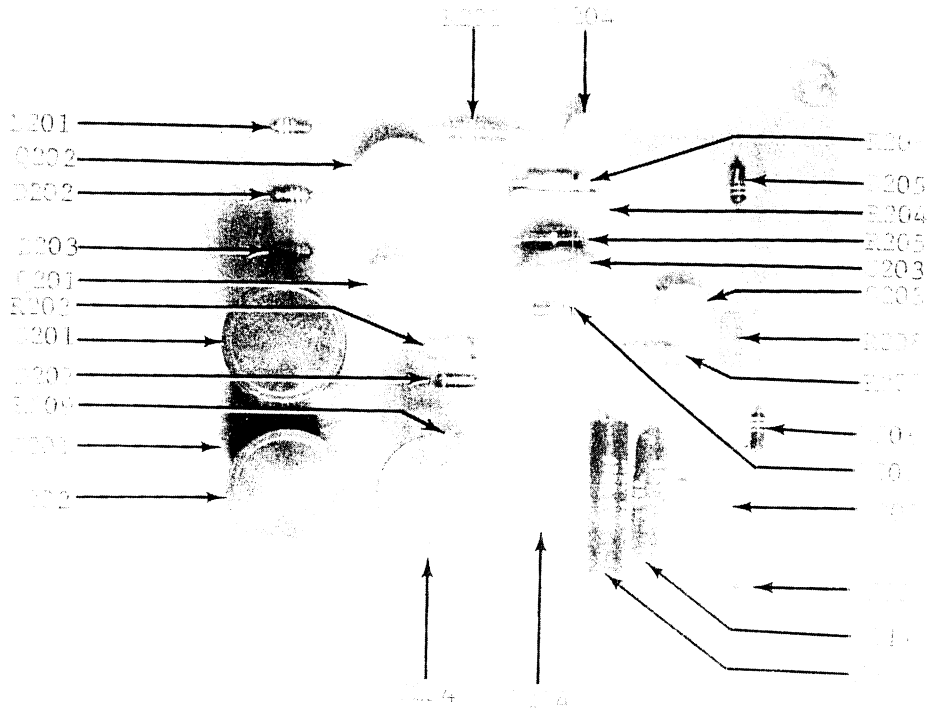

FIGURE 11. Component Locations on Printed Circuit PC-94.



FIGURE 12. Component Locations on Range Switch S102. Resistors R101 to R103 are on the opposite side of the switch.

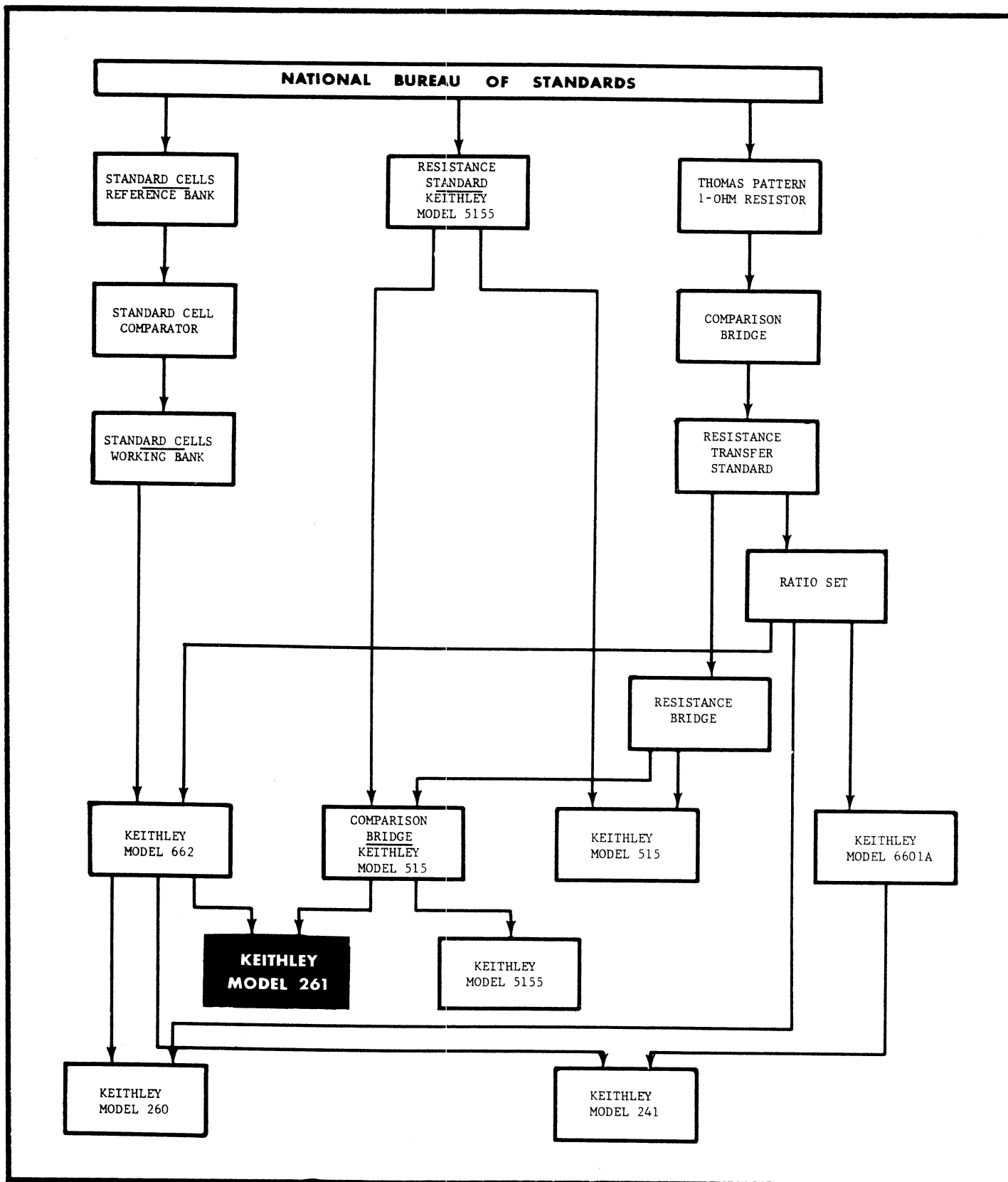

FIGURE 13. Model 261 Traceable Chart to National Bureau of Standards. Other Keithley instruments are also shown.

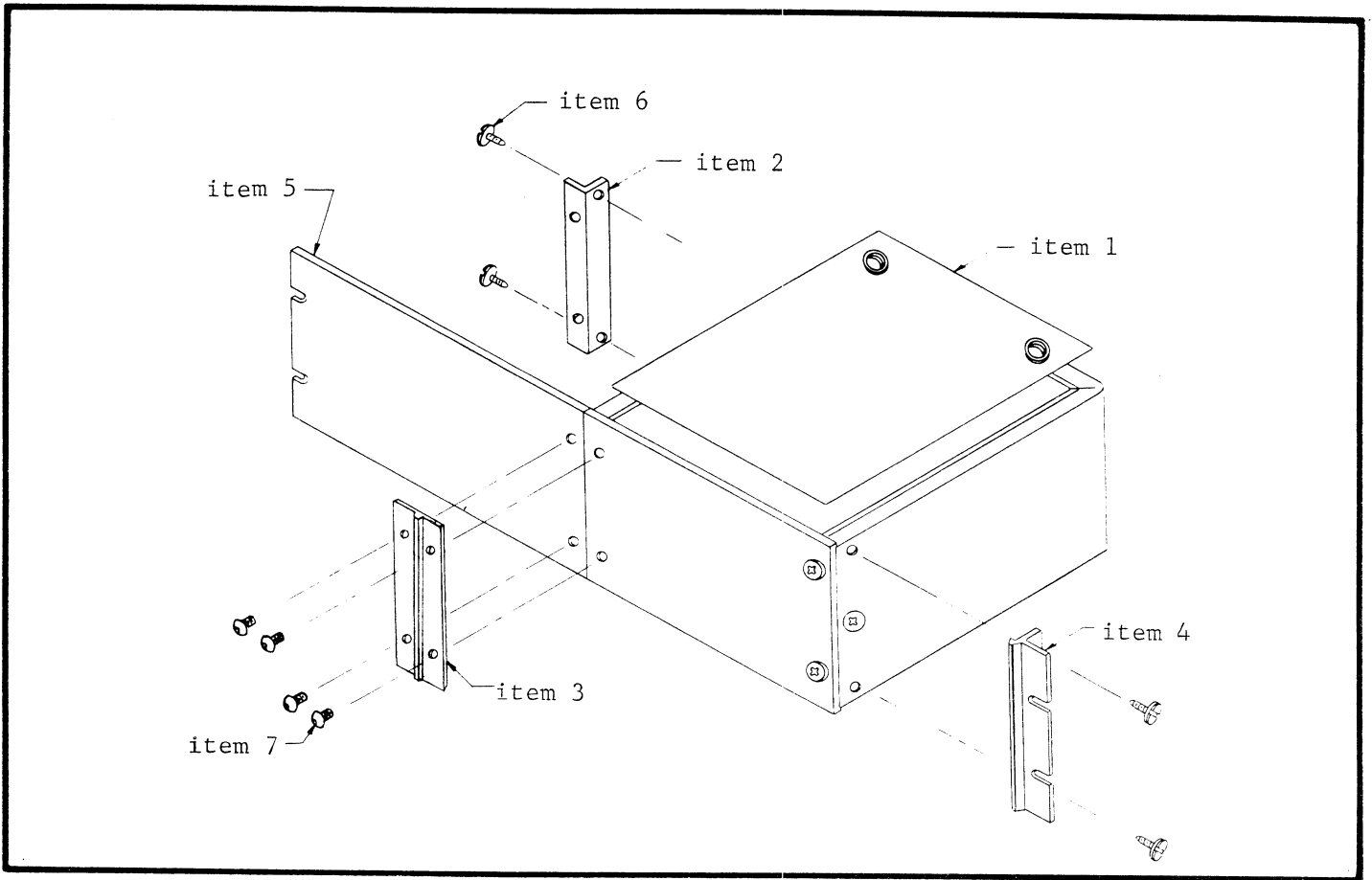

FIGURE 14. Assembly Drawing for Model 4003A Rack Mounting Kit.

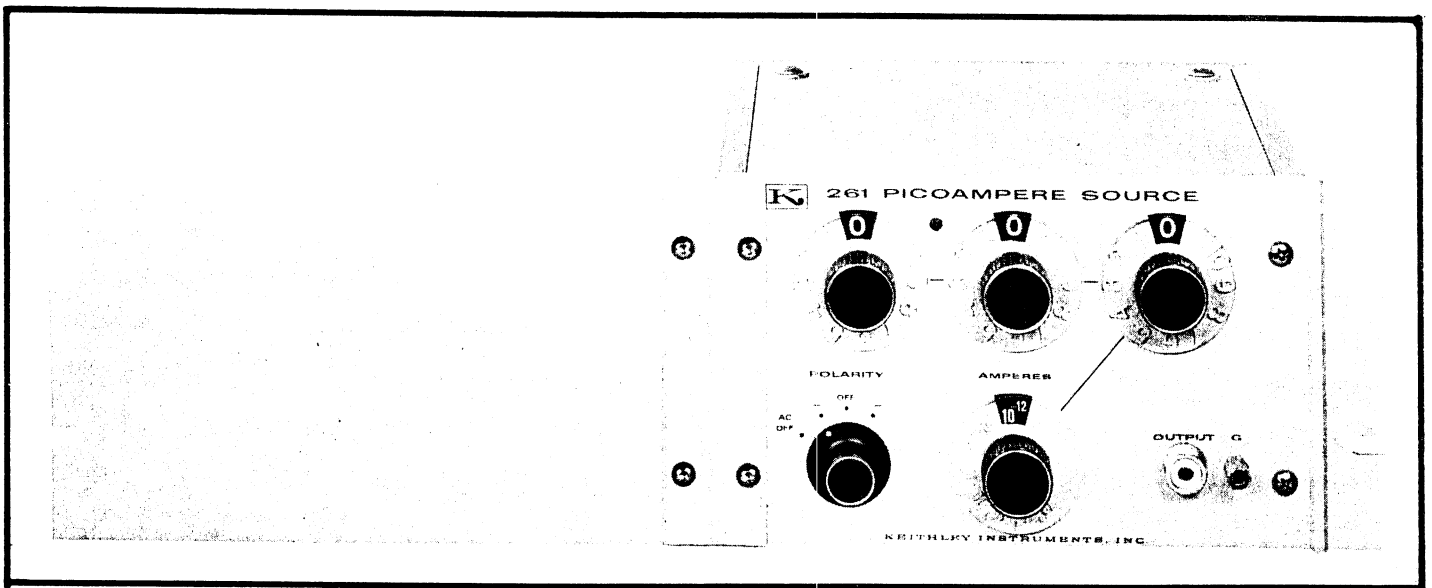

FIGURE 15. Model 261 Converted for Rack Mounting with Model 4003A Rack Mounting Kit.

## SECTION 7. ACCESSORIES

7-1. GENERAL. This Section contains instructions on using Keithley accessories with the Model 261 Picoampere Source. The principal accessories described here are the rack and bench mounting kits and the Model 6106 Electrometer Connection Kit. The Model 2611 Test Cable, furnished with the Source, is described in Section 2.

### 7-2. MODEL 4003A RACK MOUNTING KIT.

a. The Model 4003A Kit converts the Model 261 from a bench model to rack mounting. Rack dimensions are 5-1/4 inches high x 19 inches wide x 10 inches deep. The Source converts to half-rack size, and the Kit contains a half-rack adapter panel.

b. Procedures. Remove the wrap-around cover on the Source by removing the two corner screws at the bottom of each side. Add the rack mounting parts to the Source as shown in Figure 14. Attach in this order: cover (1), rack angle (4), panel support angle (2), rack panel adapter (5), and chassis connecting plate (3).

Item (See Fig. 14)	Description	Keithley Part No.	Quantity
1	Cover Assembly (cover for 10" models)	18554B	1
---	Cover Assembly (cover for 13" models)	20015B	1
2	Panel Support Angle	17476A	1
3	Chassis Connecting Plate	19126A	1
4	Rack Angle	14624B	1
5	Rack Adapter Panel	17452B	1
6	Screw, slotted head, #10 x 1/2	---	4
7	Screw, round head, hex socket, #10 x 1/2	---	4

TABLE 13. Parts List for Model 4003A Rack Mounting Kit.

### 7-3. MODEL 4004A DUAL RACK MOUNTING KIT.

a. The Model 4004A Kit converts the Model 261 to rack mounting. The assembled Kit will contain either two Model 261's or one each of Models 261 and 260 Nanovolt Source or any two 5-1/4" high Keithley half-rack instruments. Dimensions are 5-1/4 inches high x 19 inches wide x 10 inches deep.

b. Procedures. Remove the wrap-around cover on each Source by removing the two corner screws at the bottom of each side. Assemble the rack mounting parts as shown in Figure 16. If rack mounting two 10 inches deep instruments or two 13 inches deep instruments, attach in this order: cover (1), two rack angles (5), chassis connecting plate (2), and chassis connecting plate (3). If rack mounting one each 10-inch deep instrument and 13-inch deep instrument, attach in this order: cover (1), two rack angles (4), chassis connecting plate (3), and zee bracket (7).

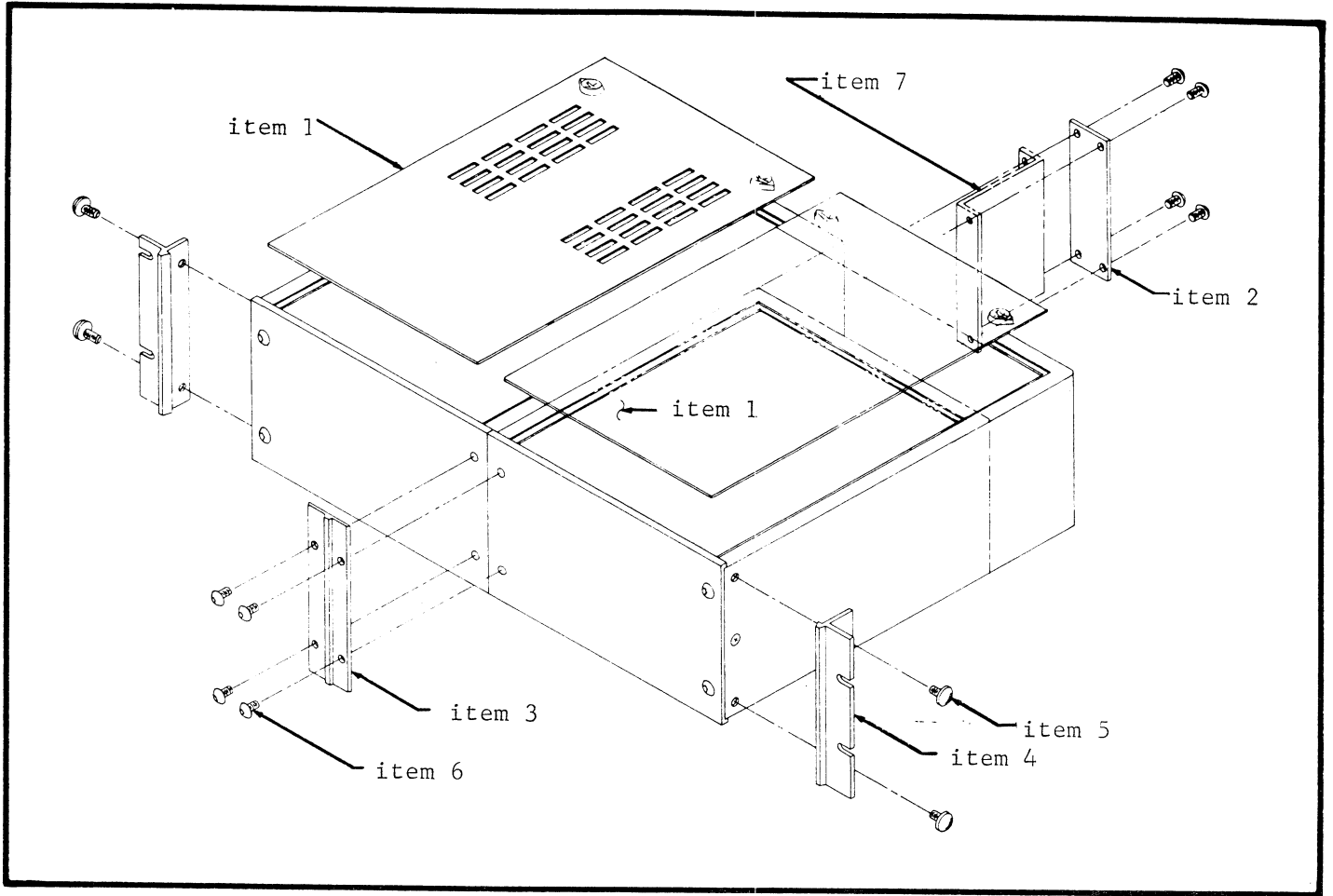

FIGURE 16. Assembly Drawing for Model 4004A Dual Rack Mounting Kit.

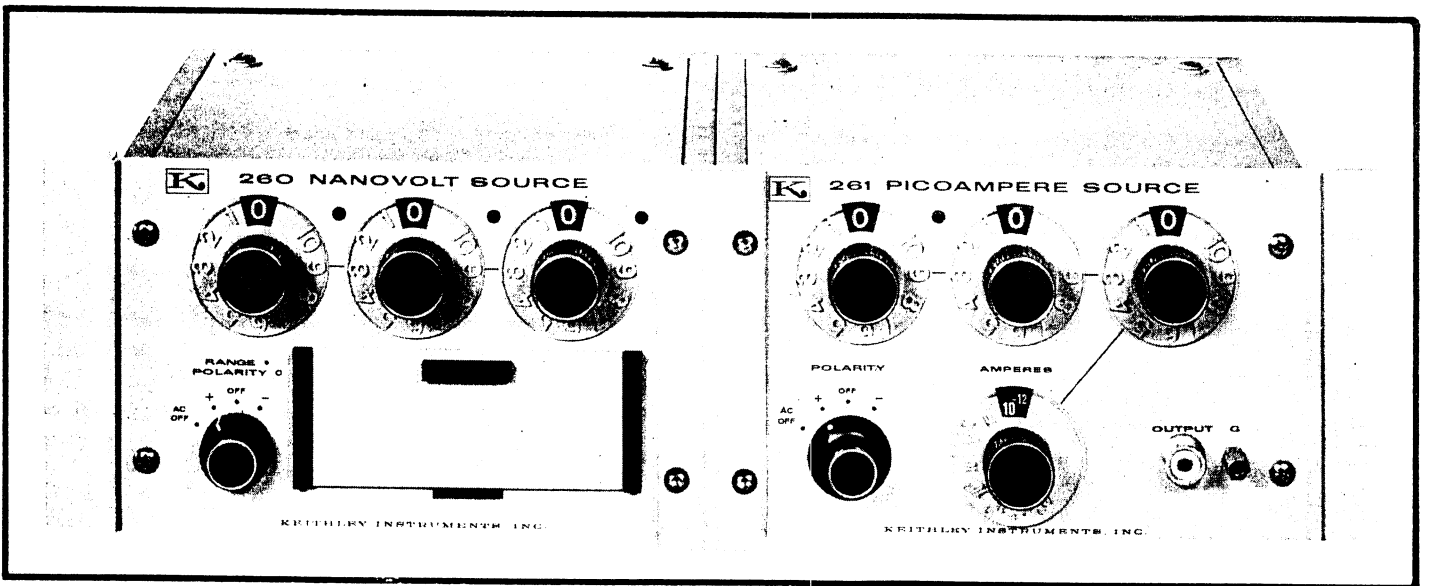

FIGURE 17. Models 260 and 261 in Dual Rack Mounting. Use the Model 4004A Kit.



Item (See Fig. 16)	Description	Keithley Part No.	Quantity
1	Cover Assembly (2 covers for 10" models)	18554B	1
---	Cover Assembly (2 covers for 13" models)	20015B	1
2	Chassis Connecting Plate	17454A	1
3	Chassis Connecting Plate	19126A	1
4	Rack Angle	14624B	2
5	Screw, slotted, #10 x 1/2	---	8
6	Screw, round head, hex socket, #10 x 1/2	---	4
7	Zee Bracket	17454A	1

TABLE 14. Parts List for Model 4004A Dual Rack Mounting Kit.

## 7-4. MODEL 3004 DUAL BENCH MOUNTING KIT.

a. The Model 3004 Kit, when assembled, will hold either two Model 261's or one each of the Models 261 and 260 Nanovolt Source. The two instruments will be contained in one easy-to-carry bench unit. Dimensions are 5-1/2 inches high x 17-1/2 inches wide x 10 inches deep.

b. Procedures. Remove the wrap-around cover on each Source by removing the two corner screws at the bottom of each side. Assemble the Kit as shown in Figure 18. Attach in this order: chassis connecting plate (2), chassis connecting plate (3), and cover (1).

## 7-5. MODEL 6106 ELECTROMETER CONNECTION KIT.

a. The Model 6106 Kit contains a group of the most useful leads and adapters for use in calibrating with the Model 261 and for electrometer measurements in general. The kit case is 2 inches high x 12 inches wide x 8 inches deep with polyethylene foam compartments. It weighs approximately three pounds.

b. The Kit contains two leads made with 30-inch low-noise coaxial shielded cable (RG 58A/U). One lead has two UHF plugs, which allow easy connections between the Model 261 and Keithley picoammeters and electrometers. (See Table 2 for model numbers.) The second lead has a UHF plug and two alligator clips. Adapters are also supplied for UHF-to-BNC conversion.

c. A UHF "tee" connector simplifies galvanometric current measurements using the Model 261 (see Figure 6).

Item (See Fig. 18)	Description	Keithley Part No.	Quantity
1	Cover Assembly	18555B	1
2	Chassis Connecting Plate	17454A	1
3	Chassis Connecting Plate	19126A	1
4	Screw, round head, hex socket #10 x 1/2	---	4
5	Screw, slotted, #10 x 1/2	---	8

TABLE 15. Parts List for Model 3004 Dual Bench Mounting Kit.

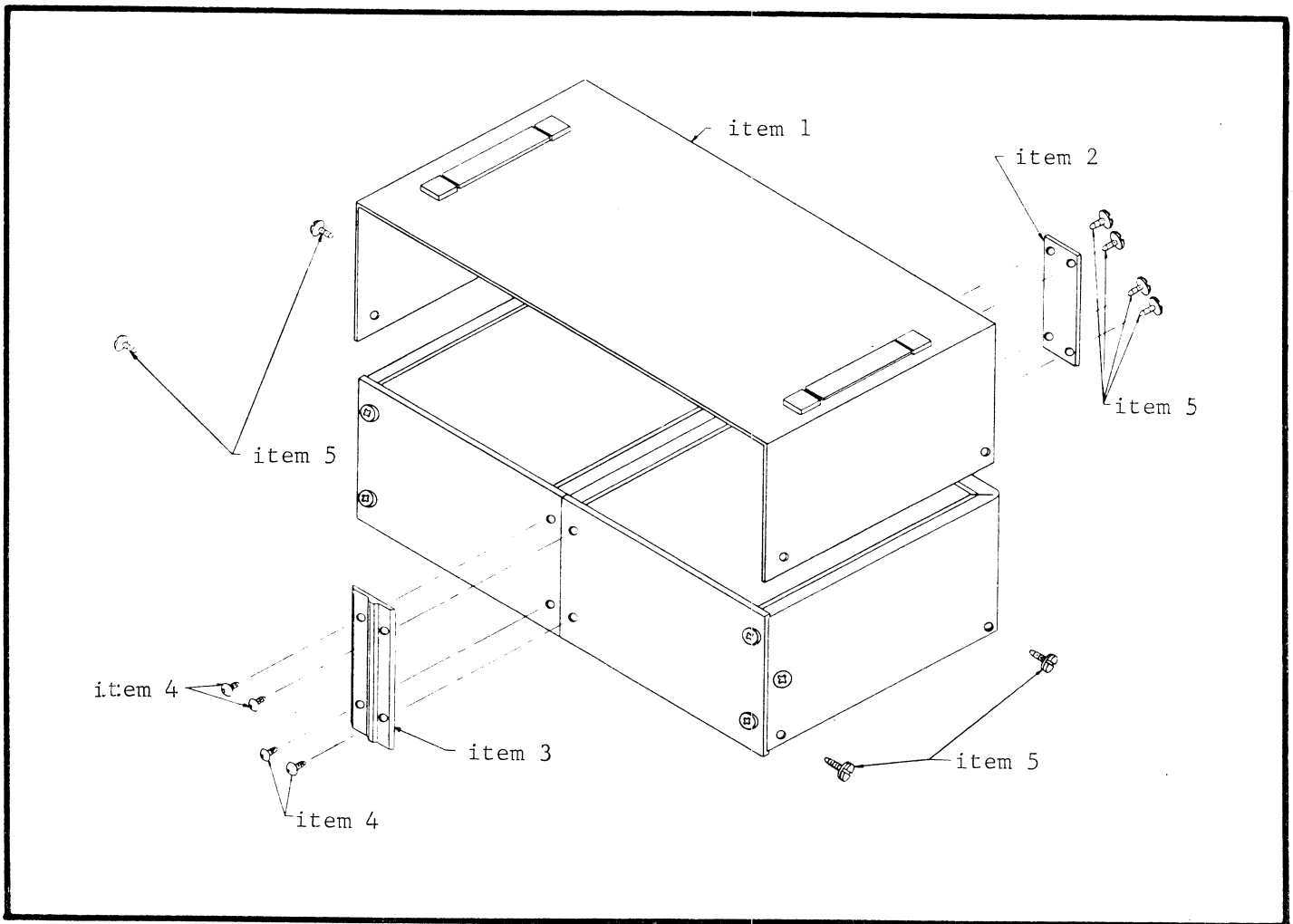

FIGURE 18. Assembly Drawing for Model 3004 Dual Bench Mounting Kit.

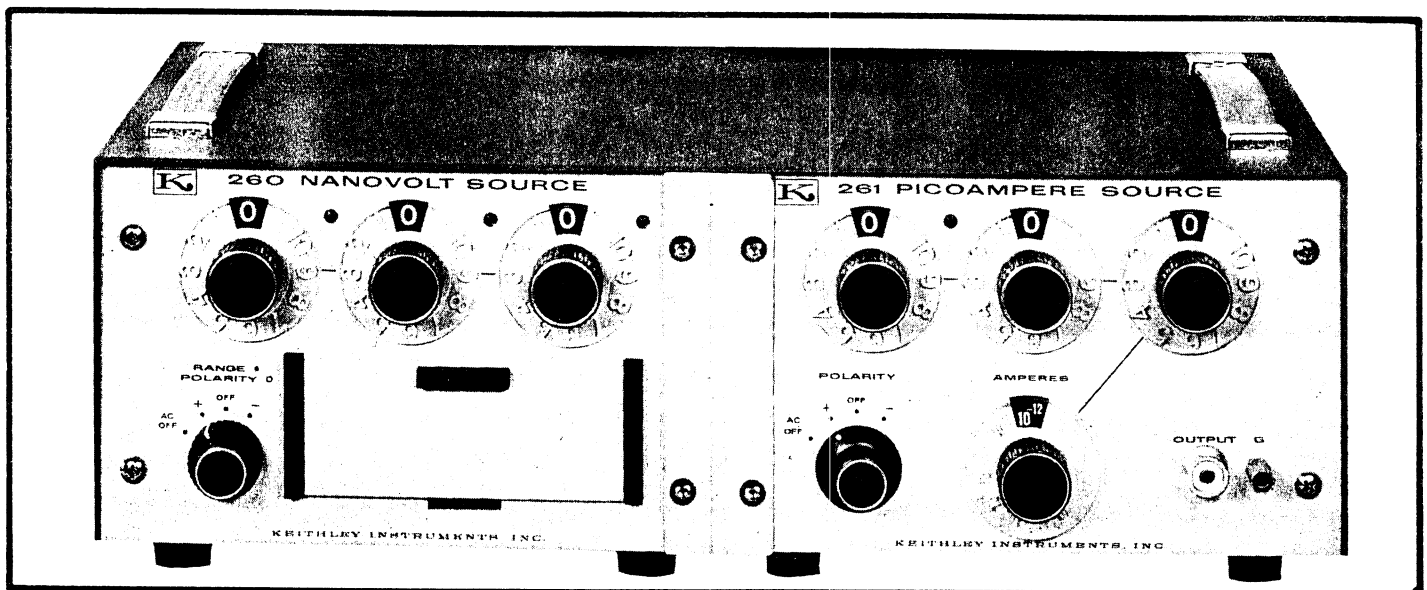

FIGURE 19. Models 260 and 261 in Dual Bench Mounting.

Item Fig. 20	Description	Keithley Part No.
1	Test Lead, two uhf plugs	18265C
2	Binding Post Adaptor, uhf plug	Model 6106-2
3	Two Connectors, female uhf to female uhf	CS-5
4	Two Connector Adaptors, female uhf to male bnc	CS-172
5	Connector, male uhf to female bnc	CS-115
6	Connector Adapter Tee, two male uhf and one female uhf	CS-171
7	Test Lead, uhf plugs and two alligator clips	Model 6106-1

TABLE 16. Contents of Model 6106 Electrometer Connection Kit.

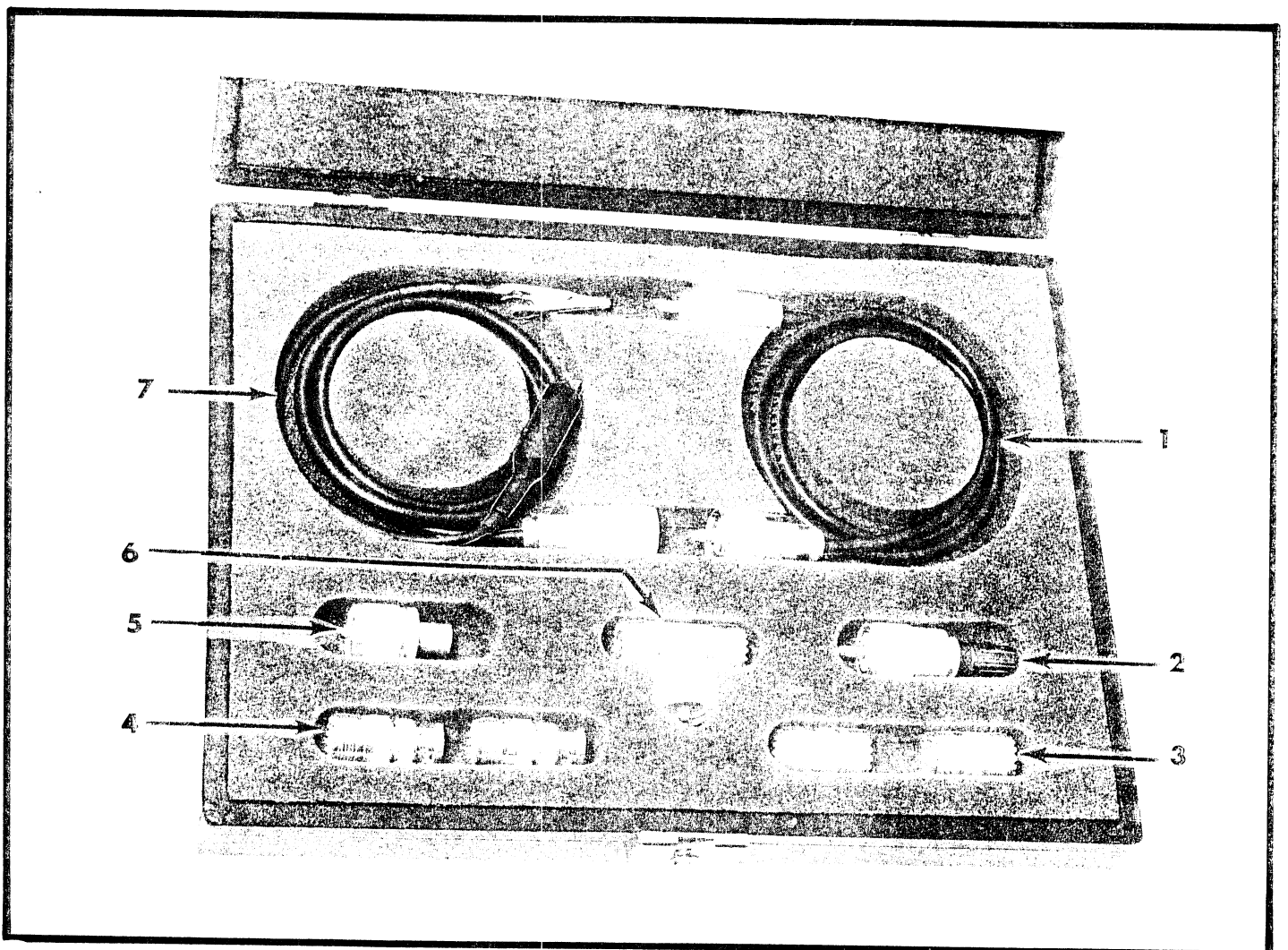

FIGURE 20. Keithley Model 6106 Electrometer Connection Kit. Refer to Table 16 for components.



## SECTION 8. REPLACEABLE PARTS

8-1. REPLACEABLE PARTS LIST. The Replaceable Parts List describes the components of the Models 261 and 2611. The List gives the circuit designation, the part description, a suggested manufacturer, the manufacturer's part number and the Keithley Part Number. The last column indicates the figure picturing the part. The name and address of the manufacturers listed in the "Mfg. Code" column are in Table 18.

### 8-2. HOW TO ORDER PARTS.

a. For parts orders, include the instrument's model and serial number, the Keithley Part Number, the circuit designation and a description of the part. All structural parts and those parts coded for Keithley manufacture (80164) must be ordered from Keithley Instruments, Inc. In ordering a part not listed in the Replaceable Parts List, completely describe the part, its function and its location.

b. Order parts through your nearest Keithley representative or the Sales Service Department, Keithley Instruments, Inc.

amp	ampere	Mil. No. My	Military Type Number Mylar
CerD Comp	Ceramic, Disc Composition	$\Omega$	ohm
DCb	Deposited Carbon	p	pico ( $10^{-12}$ )
EAl	Electrolytic, Aluminum	Ref.	Reference
f Fig.	farad Figure	$\mu$	micro ( $10^{-6}$ )
k	kilo ( $10^3$ )	v Var	volt Variable
M or meg m	mega ( $10^6$ or megohms) milli ( $10^{-3}$ )	w WW	watt Wirewound
Mfg.	Manufacturer	WWVar	Wirewound Variable

TABLE 17. Abbreviations and Symbols.

MODEL 261 REPLACEABLE PARTS LIST

(Refer to Schematic Diagram 18323E for circuit designations.)

## CAPACITORS

Circuit Desig.	Value	Rating	Type	Mfg. Code	Mfg. Part No.	Keithley Part No.	Fig. Ref.
C101	.1 $\mu$ f	50 v	My	84411	601PE	C41-.1M	12
C201	500 $\mu$ f	25 v	EA1	56289	89D231	C94-500M	11
C202	500 $\mu$ f	25 v	EA1	56289	89D231	C94-500M	11
C203	.01 $\mu$ f	1000 v	CerD	72982	811Z5V103P	C22-.01M	11
C204	500 $\mu$ f	25 v	EA1	56289	89D231	C94-500M	11

## DIODES

Circuit Desig.	Type	Number	Mfg. Code	Keithley Part No.	Fig. Ref.
D201	Silicon	1N645	01295	RF-14	11
D202	Silicon	1N645	01295	RF-14	11
D203	Silicon	1N645	01295	RF-14	11
D204	Zener	1N706	12954	DZ-1	11
D205	Silicon	1N645	01295	RF-14	11
D206	Silicon	1N645	01295	RF-14	11
D207	Zener	1N823	06751	DZ-36	11
D208	Silicon	1N645	01295	RF-14	11

## MISCELLANEOUS PARTS

Circuit Desig.	Description	Mfg. Code	Keithley Part No.	Fig. Ref.
DS201	Pilot Lamp Bulb (Mfg. No. 313)	08804	PL-21	10
—	Pilot Lamp Holder (Mfg. No. 203CE)	72765	PL-18	
F201 (117 v)	Fuse, slow blow, 1/8 amp (Mfg. Type MDL)	71400	FU-20	11
F201 (234 v)	Fuse, slow blow, 1/16 amp (Mfg. Type MDL)	71400	FU-21	
—	Fuse Holder (Mfg. No. 342012)	75915	FH-3	
J101	Binding Post, G (Mfg. No. 33-286)	08811	BP-15	2
J102	Binding Post, GND (Mfg. No. DF21GC)	58474	BP-11G	
J103	Binding Post, COM (Mfg. No. DF21BC)	58474	BP-11B	
—	Shorting Link (Mfg. No. 938-L)	24655	BP-6	
J104	Receptacle, uhf, OUTPUT, Mil. No. SO-239A (Mfg. No. 6804)	91737	CS-64	2
—	Plug, uhf, Mate of J104, Mil. No. 49190 (Mfg. No. 83-822)	02660	CS-49	
J201	Test Jack (Mfg. No. TJ300M)	81453	TJ-4	11
J202	Test Jack (Mfg. No. TJ303R)	81453	TJ-5	11

## MISCELLANEOUS PARTS (Cont'd)

Circuit Desig.	Description	Mfg. Code	Keithley Part No.	Fig. Ref.
P201	Cord Set, 6 feet (Mfg. No. 4638-13)	93656	CO-5	
—	Cable Clamp (Mfg. No. SR-5P-1)	28520	CC-4	
S101	Slide Switch, CAL-OPERATE (Mfg. No. G326)	79727	SW-45	
S102	Rotary Switch less components, AMPERES	80164	SW-180	2
—	Rotary Switch with components, AMPERES	80164	18524B	
—	Dial Assembly, Amperes Switch	80164	17937A	
S103	Rotary Switch less components, X.01 Multiplier	80164	SW-181	2
—	Rotary Switch with components, X.01 Multiplier	80164	18463B	
—	Dial Assembly, 0-10 Readout	80164	14829A	
S104	Rotary Switch less components, X.1 Multiplier	80164	SW-159	2
—	Rotary Switch with components, X.1 Multiplier	80164	18456B	
—	Dial Assembly, 0-9 Readout	80164	14828A	
S105	Rotary Switch less components, X1 Multiplier	80164	SW-182	2
—	Rotary Switch with components, X1 Multiplier	80164	18465B	
—	Dial Assembly, 0-10 Readout	80164	14829A	
S106	Rotary Switch, POLARITY	80164	SW-189	2
—	Knob Assembly, Polarity Switch	80164	14838A	
S201	Slide Switch, 117-234 v	80164	SW-151	10
T201	Transformer	80164	TR-78	10

## RESISTORS

Circuit Desig.	Value	Rating	Type	Mfg. Code	Mfg. Part No.	Keithley Part No.	Fig. Ref.
R101	100 k $\Omega$	.02%, 1/2 w	WW	15909	1252	R47-100K	12
R102	1 M $\Omega$	1%, 1/2 w	DCb	79727	CFE-15	R12-1M	12
R103	10 M $\Omega$	1%, 1/2 w	DCb	79727	CFE-15	R12-10M	12
R104	100 M $\Omega$	1%, 2 w	DCb	80164		18087A	12
R105	10 <sup>9</sup> $\Omega$	1%	DCb	80164		18086A	12
R106	10 <sup>10</sup> $\Omega$	1%	DCb	80164		18085A	12
R107	10 <sup>11</sup> $\Omega$	1%	DCb	80164		18084A	12
R108	10 <sup>12</sup> $\Omega$	1%	DCb	80164		18083A	12
R109	10 M $\Omega$	10%, 1/2 w	Comp	01121	EB	R1-10M	12
R110	1.5 M $\Omega$	10%, 1/2 w	Comp	01121	EB	R1-1.5M	12
R111	150 k $\Omega$	10%, 1/2 w	Comp	01121	EB	R1-150K	12
R112	Not used						
R113	200 $\Omega$	10%, 5 w	WWVar	71450	AW	RP3B-200	10
R114	200 $\Omega$	10%, 5 w	WWVar	71450	AW	RP3B-200	10
R115	200 $\Omega$	10%, 5 w	WWVar	71450	AW	RP3B-200	10

\* Nominal value, factory set.

## RESISTORS (Cont'd)

Circuit Desig.	Value	Rating	Type	Mfg. Code	Mfg. Part No.	Keithley Part No.	Fig. Ref.
R116	200 $\Omega$	10%, 5 w	WWVar	71450	AW	RP3B-200	10
R117	200 $\Omega$	10%, 5 w	WWVar	71450	AW	RP3B-200	10
R118	200 $\Omega$	10%, 5 w	WWVar	71450	AW	RP3B-200	10
R119	200 $\Omega$	10%, 5 w	WWVar	71450	AW	RP3B-200	10
R120	12.8 $\Omega$	.1%, 1/2 w	WW	15909	1142	R67-12.8	10
R121	12.8 $\Omega$	.1%, 1/2 w	WW	15909	1142	R67-12.8	10
R122	12.8 $\Omega$	.1%, 1/2 w	WW	15909	1142	R67-12.8	10
R123	12.8 $\Omega$	.1%, 1/2 w	WW	15909	1142	R67-12.8	10
R124	12.8 $\Omega$	.1%, 1/2 w	WW	15909	1142	R67-12.8	10
R125	12.8 $\Omega$	.1%, 1/2 w	WW	15909	1142	R67-12.8	10
R126	12.8 $\Omega$	.1%, 1/2 w	WW	15909	1142	R67-12.8	10
R127	12.8 $\Omega$	.1%, 1/2 w	WW	15909	1142	R67-12.8	10
R128	12.8 $\Omega$	.1%, 1/2 w	WW	15909	1142	R67-12.8	10
R129	12.8 $\Omega$	.1%, 1/2 w	WW	15909	1142	R67-12.8	10
R130	12.8 $\Omega$	.1%, 1/2 w	WW	15909	1142	R67-12.8	10
R131	12.8 $\Omega$	.1%, 1/2 w	WW	15909	1142	R67-12.8	10
R132	12.8 $\Omega$	.1%, 1/2 w	WW	15909	1142	R67-12.8	10
R133	12.8 $\Omega$	.1%, 1/2 w	WW	15909	1142	R67-12.8	10
R134	12.8 $\Omega$	.1%, 1/2 w	WW	15909	1142	R67-12.8	10
R135	12.8 $\Omega$	.1%, 1/2 w	WW	15909	1142	R67-12.8	10
R136	12.8 $\Omega$	.1%, 1/2 w	WW	15909	1142	R67-12.8	10
R137	12.8 $\Omega$	.1%, 1/2 w	WW	15909	1142	R67-12.8	10
R138	12.8 $\Omega$	.1%, 1/2 w	WW	15909	1142	R67-12.8	10
R139	12.8 $\Omega$	.1%, 1/2 w	WW	15909	1142	R67-12.8	10
R140	12.8 $\Omega$	.1%, 1/2 w	WW	15909	1142	R67-12.8	10
R141	64 $\Omega$	.1%, 1/2 w	WW	15909	1142	R67-64	10
R142	64 $\Omega$	.1%, 1/2 w	WW	15909	1142	R67-64	10
R143	64 $\Omega$	.1%, 1/2 w	WW	15909	1142	R67-64	10
R144	64 $\Omega$	.1%, 1/2 w	WW	15909	1142	R67-64	10
R145	64 $\Omega$	.1%, 1/2 w	WW	15909	1142	R67-64	10
R146	64 $\Omega$	.1%, 1/2 w	WW	15909	1142	R67-64	10
R147	64 $\Omega$	.1%, 1/2 w	WW	15909	1142	R67-64	10
R148	64 $\Omega$	.1%, 1/2 w	WW	15909	1142	R67-64	10
R149	64 $\Omega$	.1%, 1/2 w	WW	15909	1142	R67-64	10
R150	64 $\Omega$	.1%, 1/2 w	WW	15909	1142	R67-64	10
R151	64 $\Omega$	.1%, 1/2 w	WW	15909	1142	R67-64	10
R152	64 $\Omega$	.1%, 1/2 w	WW	15909	1142	R67-64	10
R153	32 $\Omega$	.1%, 1/2 w	WW	15909	1142	R67-32	10
R201	760 $\Omega$	1%, 1/2 w	WW	01686	E-30	R58-760	11
R202	2.2 k $\Omega$	10%, 1/2 w	Comp	01121	EB	R1-2.2K	11
R203	10 k $\Omega$	10%, 1/2 w	Comp	01121	EB	R1-10K	11



## RESISTORS (Cont'd)

Circuit Desig.	Value	Rating	Type	Mfg. Code	Mfg. Part No.	Keithley Part No.	Fig. Ref.
R204	3.3 $\Omega$	1%, 1/2 w	DCb	79727	CFE-15	R12-3.3	11
R205	1.5 k $\Omega$	10%, 1/2 w	Comp	01121	EB	R1-1.5K	11
R206	10 k $\Omega$	10%, 1/2 w	Comp	01121	EB	R1-10K	11
R207	634 $\Omega$	10%, 1/2 w	Comp	01121	EB	R1-634	11
R208	4.7 k $\Omega$	10%, 1/2 w	Comp	01121	EB	R1-4.7K	11
R209	2.7 k $\Omega$	10%, 1/2 w	Comp	01121	EB	R1-2.7K	11
R210	200 $\Omega$	10%, 5 w	WWVar	71450	AW	RP3B-200	10
R211	*470 $\Omega$	1%, 1/2 w	WW	01686	E-30	R58-470	11

## TRANSISTORS

Circuit Desig.	Number	Mfg. Code	Keithley Part No.	Fig. Ref.
Q201	2N1381	01295	TG-8	11
Q202	2N1183	02735	TG-11	11
Q203	2N1381	01295	TG-8	11
Q204	2N1381	01295	TG-8	11
Q205	2N1381	01295	TG-8	11

MODEL 2611 REPLACEABLE PARTS LIST

Description	Mfg. Code	Keithley Part No.
Plug, two req'd, uhf, Mate of Model 261, Mil. No. 49190 (Mfg. 83-822)	02660	CS-49
Reducing Adapter, two req'd, uhf, Mil. No. UG-175/U (Mfg. No. 83-185)	02660	CS-36
Shielded Cable	80164	18264B

01121	Allen-Bradley Corp. Milwaukee, Wis.	02660	Amphenol-Borg Electronics Corp. Broadview, Chicago, Illinois
01295	Texas Instruments, Inc. Semi-Conductor-Components Division Dallas, Texas	02735	Radio Corp. of America Commercial Receiving Tube and Semiconductor Division Somerville, N. J.
01686	RCL Electronics, Inc. Riverside, N. J.	04713	Motorola, Inc. Semiconductor Products Division Phoenix, Arizona

TABLE 18 (Sheet 1). Code List of Suggested Manufacturers. (Based on Federal Supply Code for Manufacturers, Cataloging Handbook H4-1.)

08804	Lamp Metals and Components Department G. E. Co. Cleveland, Ohio	72765	Drake Mfg. Co. Chicago, Ill.
08811	G-C Electronics Co., Inc. Camden, N. J.	72982	Erie Technological Products, Inc. Erie, Pa.
12954	Dickson Electronics Corp. Scottsdale, Ariz.	75915	Littelfuse, Inc. Des Plaines, Ill.
15909	Daven Division Thomas A. Edison Industries McGraw Edison Co., Livingston, N. J.	79727	Continental-Wirt Electronics Corp. Philadelphia, Pa.
24655	General Radio Co. West Concord, Mass.	80164	Keithley Instruments, Inc. Cleveland, Ohio
28520	Heyman Mfg. Co. Kenilworth, N. J.	81453	Raytheon Co. Industrial Components Div. Industrial Tube Operation Newton, Mass.
56289	Sprague Electric Co. North Adams, Mass.	83125	General Instrument Corp. Capacitro Division Darlington, S. C.
58474	Superior Electric Co., The Bristol, Conn.	84411	Good-All Electric Mfg. Co. Ogallala, Nebr.
63060	Victoreen Instrument Co. Cleveland, Ohio	91637	Dale Electronics, Inc. Columbus, Nebr.
71400	Bussmann Mfg. Div. of McGraw-Edison Co. St. Louis, Mo.	91737	Gremer Mfg. Co., Inc. Wakefield, Mass.
71450	CTS Corp. Elkhart, Ind.	93656	Electric Cord Co. Caldwell, N. J.

TABLE 18 (Sheet 2). Code List of Suggested Manufacturers. (Based on Federal Supply Code for Manufacturers, Cataloging Handbook H4-1.)

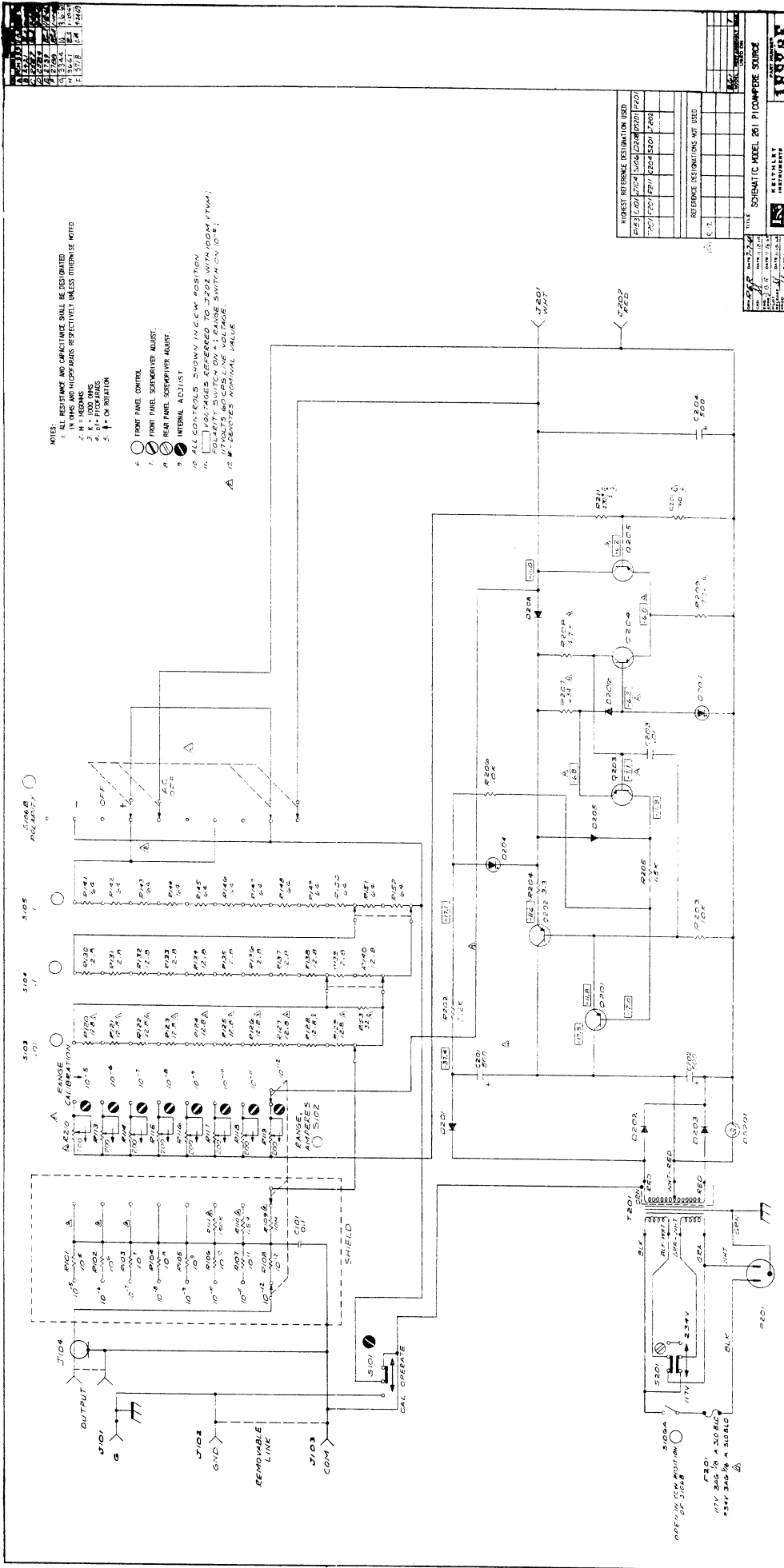

- NOTES:
1. ALL RESISTANCE AND CAPACITANCE SHALL BE DESIGNATED IN OHMS AND MICROHMS RESPECTIVELY UNLESS OTHERWISE NOTED
  2. K = 1000 OHMS
  3. M = 1000 MICROHMS
  4. DI = PICO DIODES
  5. ↓ = OF ISOLATION
6. FRONT PANEL CONTROL
  7. FRONT PANEL SCORING/ADJUST.
  8. REAR PANEL SCORING/ADJUST.
  9. INTERNAL ADJUST.
10. ALL CONTROLS, UNLESS INDICATED OTHERWISE, TO BE IN THE NORMAL POSITION.
  11. VOLTAGE REFERENCE IS 2.3V ± 0.004% (100 μV TYP.).
  12. POLARITY SWITCH ON ±1 RANGE SWITCH ON (0.5).
  13. VOLTAGE AND CURRENT LINE VOLTAGE SWITCH ON (0.5).
  14. W = WATERS NATIONAL VALUE

HIGHEST REFERENCE DESIGNATION USED	
R206	2.3V
C204	100 pF
O202	741
O201	741
P108	100 k
P107	100 k
P106	100 k
P105	100 k
P104	100 k
P103	100 k
P102	100 k
P101	100 k
R108	100 k
R107	100 k
R106	100 k
R105	100 k
R104	100 k
R103	100 k
R102	100 k
R101	100 k

SCHEMATIC MODEL 261 PICOAMPERE SOURCE  
 WATERS NATIONAL INSTRUMENTS  
 18378E

-37.47  
 output 2.10 V





KEITHLEY INSTRUMENTS, INC.

28775 AURORA ROAD • CLEVELAND, OHIO 44139 • (216) 248-0400  
TELEX: 98-5469 • CABLE: KEITHLEY

